



AELIO-P50B100

AELIO-P60B100

Maintenance Manual

Version 1.0

www.solaxpower.com



STATEMENT

Copyright

Copyright © SolaX Power Network Technology (Zhejiang) Co., Ltd. All rights reserved.

No part of this manual may be reproduced, transmitted, transcribed, stored in a retrieval system, or translated into any language or computer language, in any form or by any means without the prior written permission of SolaX Power Network Technology (Zhejiang) Co., Ltd.

Trademarks



SOLA X and other symbol or design (brand name, logo) that distinguishes the products or services offered by SolaX has been trademark protected. Any unauthorized use of the above stated trademark may infringe the trademark right.

Notice

Please note that certain products, features, and services mentioned in this document may not be within the scope of your purchase or usage. Unless otherwise specified in the contract, the contents, information, and recommendations presented in this document are provided "as is" by SolaX. We do not provide any warranties, guarantees, or representations, whether express or implied.

The content of the documents is reviewed and updated as needed. However, occasional discrepancies may occur. SolaX retains the right to make improvements or changes in the product(s) and the program(s) described in this manual at any time without prior notice.

The images included in this document are solely for illustrative purposes and may differ based on the specific product models.

For more detailed information, kindly visit the website of SolaX Power Network Technology (Zhejiang) Co., Ltd. at www.solaxpower.com.

SolaX retains all rights for the final explanation.

About This Manual

Scope of Validity

This document describes routine maintenance, troubleshooting, and parts replacement of AELIO-P50B100 and AELIO-P60B100 product. Please read it carefully before maintaining.





Target Group

This document is intended for:

- Technical support engineers
- Maintenance engineers

Conventions

The symbols that may be found in this manual are defined as follows.

Symbol	Description
 DANGER	Indicates a hazardous situation which, if not avoided, will result in death or serious injury.
 WARNING	Indicates a hazardous situation which, if not avoided, could result in death or serious injury.
 CAUTION!	Indicates a hazardous situation which, if not avoided, could result in minor or moderate injury.
 NOTICE!	Provides tips for the optimal operation of the product.

Change History

Version 01 (2024-10-30)

Modify the structure of the EPS area

Modify the Australian user service mailbox

Version 00 (2024-09-20)

Initial release

Table of Contents

1	Safety	1
1.1	General Safety	1
1.2	Personal Safety	2
1.3	Environment Requirement	3
1.4	Cabinet, Battery and Electric Safety	4
1.4.1	Cabinet Safety	4
1.4.2	Battery Safety	7
1.4.3	Electrical Safety	11
1.5	Safety Instructions of PV, Inverter and Grid	14
1.5.1	Safety Instructions of PV	14
1.5.2	Safety Instructions of Inverter	15
1.5.3	Safety Instructions of Utility Grid	16
2	Routine Maintenance	17
2.1	Preparations Before Maintenance	17
2.2	Routine Maintenance	18
2.3	Power Off	20
2.4	Power On	27
3	Alarm Reference	34
3.1	Cabinet Screen	34
3.1.1	Logging in	34
3.1.2	Viewing Alarms	35
3.2	EMS1000 Webpage	37
3.2.1	Logging in	37
3.2.2	Viewing Alarms	38
3.3	SolaX Cloud App	40
3.3.1	Downloading and Installing App	40
4	Replacement of Battery Pack	42
5	Replacement of Battery Pack Fan	48
6	Replacement of BMU	52
7	Replacement of High-voltage Box	57
8	Replacement of SBMU	62
9	Replacement of High-voltage Box Fuse	68

10 Replacement of High-voltage Box Contactor..... 75

11 Replacement of EMS..... 83

12 Replacement of I/O Module..... 88

13 Replacement of UPS 93

14 Replacement of HUB 97

15 Replacement of Air Conditioner.....100

16 Replacement of Temperature and Humidity Sensor 104

17 Replacement of Door Sensor..... 106

18 Replacement of Smoke Detector and Temperature Sensor..... 109

19 Replacement of Distribution Box 111

20 Replacement of SPD Module 119

21 Replacement of Audible and Visible Alarm 123

22 Replacement of Toxic Gases Detector..... 126

23 Replacement of Water Sensor 128

24 Replacement of EPS Switch..... 130

25 Replacement of UPS Switch 133

26 Replacement of Inverter Fans 136

27 Replacement of Inverter..... 142

28 Checking after Replacement..... 143

1 Safety

1.1 General Safety

Before transporting, storing, installing, operating, using and/or maintaining the equipment, please carefully read the document, and strictly follow the instructions and safety precautions given herein, as well as symbols affixed on the equipment.

The operator should not only abide by all safety precautions provided in the document, including but not limited to the "Danger" sign, "Warning" sign, "Caution" sign, and "Notice" sign, but also comply with relevant international, national and local laws and regulations, and industry rules. **SolaX will not assume any responsibilities for the loss caused by improper operation, or violation of safety standards for design, production and equipment suitability.**

SolaX will not be liable for maintenance for possible device failure, device malfunction, or parts damage, nor **will the company assume any liability to pay compensation for the possible physical and property damage** resulting from the installation environment that does not meet the design requirements.

The operator should comply with the local laws, regulations, standards and guidelines in the process of transportation, storage, installation, operation, and maintenance.

The device is well designed and tested to meet all applicable states and international safety standards. However, like all electrical and electronic equipment, safety precautions must be observed and followed during the installation of the device to reduce the risk of personal injury and to ensure a safe installation.

Before installing the device, carefully read, fully understand and strictly follow the detailed instruction of the *User Manual* and other related regulations. And the safety instructions in this document are only supplements to local laws and regulations.

SolaX will not assume any responsibilities if any of the following circumstances occurs, including but not limited to:

- Device damage due to force majeure, such as earthquake, flooding, thunderstorm, lighting, fire hazard, volcanic eruption, war, typhoon, tornado, etc.
- Device damage due to man-made cause.
- Device used or operated against local policy or regulations.
- Failure to follow the operation instructions and safety precautions on the product and in this document.
- Installation and use under improper environment or electrical condition.
- Unauthorized modifications to the product or software.
- Device damage caused during transportation by the customer or the third party.
- Storage conditions that do not meet the requirements specified in this document

- Use of incompatible inverters or devices.
- Installation and commissioning operated by unauthorized personnel who are not licensed and /or satisfy state and local jurisdiction regulations.

1.2 Personal Safety

DANGER!

- Do not power on while installing the device. If the device is powered on in the process of installation and disassembly of cables, an electric arc, electric spark or fire will occur at the moment that the cable core contacts conductors. It may cause a fire or result in physical and property damage.
- Do not improperly operate while powering on. Any improper operation may cause a fire, electric shock, or explosion, and it will result in physical and property damage.
- Must remove rings, bracelets, watches, and any other metal jewelry from fingers, hands, or wrists before operation, to avoid electrical shock or burn.
- Must use special insulation tools, of which the insulation grade and dielectric strength level must be consistent with local laws, regulations, standards, and guidelines, in the operation process, to avoid electrical shock, burn, or short circuit fault.

WARNING!

- Must wear special personal protective equipment (PPE), such as a coverall, safety boots, safety glasses, safety helmet, safety gloves, etc.

CAUTION!

- Do not stop the safety switch on the device, and neglect the "Danger" sign, "Warning" sign, "Caution" sign, and "Notice" sign on the device, as well as safety precautions in the document.
- Must stop working at once, report to the relevant person in charge, and activate protection schemes in case of possible danger that may cause human injury and damage to device in the installation and operation process.
- Do not power on during the installation process, or before obtaining confirmation from professionals after finishing installation.
- Do not directly contact power supply device, or contact it with other conductors or wet objects.
- Do not touch the running fan with parts, screws, or installation tools, or keep hands clear when the fan is running, to avoid personal injury or property damage.
- Please evacuate and press the fire bell immediately, or call fire department at once in the case of a fire.

1.3 Environment Requirement

DANGER!

The device installation site shall meet the following requirements:

- Keep away from combustibles and explosive materials.
- Keep away from heat or fire sources, such as fireworks, candles, heaters, or any other heat-producing appliances. It may cause damage to device or a fire.
- Keep away from flammable and explosive gases, or smoky environments.

WARNING!

- The device installation site should keep away from liquid areas, such as positions under a water pipe or air outlet where the condensed water is easy to form, or positions under an air-conditioning vent, ventilation opening or device room outlet where there is access to water. The water can seep into the internal components of the device, causing device damage and short circuits.
- Do not cover vents and cooling systems while running. Otherwise, it may cause a fire or device damage due to the high temperature.
- Do not try to open the cabinet doors on a rainy or high humid day (humidity equal to or greater than 80%). If the cabinet doors happen to be opened on a rainy day, a covering must be arranged to protect the modules in it from water. If the cabinet doors have been opened for over 30 minutes on a highly humid day when the cabinet is off-grid or under grid connection, the operator needs to manually dehumidify. Otherwise, it may not work properly or not connect to the network properly.

CAUTION!

- The storage area should be clean, dry, and well ventilated to prevent dust from entering, and condensed water from generating.
- Strictly observe technical specifications while installing and running the device. Or, it may affect the performance and safety of the device.
- Do not install, run or operate outdoor device or cables (including but not limited to carrying device, operating device, connecting cables, plugging or unplugging cables that connect to outdoor signal ports, working at heights, outdoor installation, etc.) in bad weather, such as thunderstorms, rain, snow, etc.
- Keep away from the following environments while installing the device: environments with dust, smoke, volatile gases, corrosive gases, infrared radiation, organic solvents, or a site with high salt.
- Keep away from environments with metal-conductive or magnetic-conductive dust.
- Keep away from areas suitable for fungus, mould, or other microorganism growth.
- Keep away from areas with strong shaking, serious noise pollution, or powerful electromagnetic interference.
- The installation site must conform to local laws and regulations, and relevant standards.

 CAUTION!

- The ground at the installation site must be firm and strong instead of having an adverse geological condition, such as soil with high water content, weak soils, or loose soils. And keep away from low-lying areas since they are prone to water or snow accumulation.
- Keep away from areas prone to water accumulation.
- If the device is installed on a grassy plantation, do weed regularly, and harden the ground under the device, such as cementing, gravelling, etc.
- When the operator plans to install, operate or maintain the device, water, snow, or other objects must be cleared on the top of the device before opening doors to keep them from entering into the device.
- Please check the ground is firm and strong enough to meet the load-bearing requirements of the device while it is being installed.
- Must seal the entry holes.
- Must clean the packing materials, such as cartons, foams, plastic bags, ties, etc., on the site after finishing installation.

1.4 Cabinet, Battery and Electric Safety

To prevent personal injury or property damage from improper operation, please carefully read the following installation precautions before installation.

1.4.1 Cabinet Safety

 DANGER!

- A safety helmet, belt, or rope must be worn when performing work at height. If the safety rope is adopted, one end must be securely tied to a strong structural part instead of a movable and unsound object or a metal with sharp edges, to prevent fall incidents due to the slip of the rope hook.

 WARNING!

- To ensure that a complete set of tools is prepared, are firm and secure. They must pass the verification of professional authorities. DO NOT use any tools that are broken, failed to verify, or are expired.
- To prevent personal injury or device damage from slopping or collapsing of the cabinet because it is unstable, please check if the cabinet has been secured before placing any devices into it.
- To protect relevant people from injury, take care of the unstable or heavy devices in the cabinet when taking them out.

 **WARNING!**

- Do not drill holes in the device. Otherwise, the sealing performance, electromagnetic shielding performance, or internal components or cables of the device will be destroyed, and it can even cause a short circuit on a circuit board if the metal dust generated by drilling enters into the device.

 **CAUTION!****Safety precautions for lifting and handling heavy devices:**

- To prevent injury from oversize loads, assess the device you're about to lift before you start lifting.
- If more than 2 people lift a device, reasonably arrange to have a balanced weight distribution
- Wear personal protective equipment, such as, safety gloves, safety boots, etc., to prevent needless injuries when lifting devices with bare hands.
- Know the right body posture to prevent personal injuries when lifting devices, for instance, bend at your knees, not at your waist or back, and do not twist your back.
- Hold the handles on the device or put your hands underneath the device to move or lift, and do not hold the handles on the parts installed in it.
- To prevent injuries, do not quickly lift the heavy device above the waist.
- To prevent scratches and dents, or damage to components and cables, avoid impact and falling when moving.
- Be aware of workbenches, slopes, steps, and other places where it is easy to slip when moving devices. Ensure that the passageways are smooth, clean, and away from obstacles.
- To prevent tipover, the forklift's forks must be placed under the load. Center the weight of the load between the forks, and adjust the forks to distribute the weight evenly. Firmly attach the loads to the forks before lifting, and arrange for people to watch for when lifting.
- Sea and road (in good condition) transports are an idea for the device instead of rail and air transports. Transport staff should do their best to avoid bumpiness and inclination as much as possible.

 **CAUTION!****Safety precautions for working at heights:**

- Arrange people to protect workers who work at 2 meters in height or higher.
- Workers who work at 2 meters in height or higher are required to be trained and obtain relevant qualifications.
- In the case of one of the following circumstances, workers should immediately stop operation until the device is inspected and confirmed safe by the relevant safety director and technicians.
 1. Wet steel pipe.
 2. Other situations may be dangerous.

 CAUTION!

- Should mark off a dangerous area, put up Danger signs, and keep unauthorized people from entering the area.
- Should install guardrails and put up "Watch Your Step" and Danger signs at the edges of workplace and holes.
- Do not stack scaffoldings, gangplanks, or other sundries, and keep the ground service staff from staying or passing under the area where the work is being carried out.
- Take caution with the apparatus and tools brought to ensure that they do not fall.

 CAUTION!

Safety precautions for working at heights:

- Workers who work at heights should take advantage of crane slings, baskets, elevating transfer vehicles, cranes, or other methods to transfer objects instead of throwing them from the air to the ground or from the ground to the air.
- Should avoid working on the up and down work platform at the same time. Or, a special protective shed should be built or some protective measures should be taken between two work platforms to protect workers. In addition, do not stack tools and materials on the upper work platform.
- The scaffoldings should be removed from top to bottom instead of being removed at the same time after finishing installation. Take caution when dismantling parts of scaffolding.
- Workers who work at heights must abide by the Safety Regulation for Working at Heights. SolaX will not be liable for personal injury or device damage due to violations of the Regulation.
- Do not play and have a break in the area while working at heights.

 CAUTION!

Ladder safety:

- A wood or insulated ladder should be used when working with electricity.
- A platform ladder with handrails is preferred instead of a straight ladder.
- Check that the ladder is in good condition, make sure that the load bearing meets requirements, and strictly prohibit overload.
- Place the ladder on a solid and firm surface, and designate a person to hold it.
- Balance your body to prevent injuries when climbing.
- Make sure that the rope is fastened and secured when using the herringbone ladder to prevent incidents.

 CAUTION!**Crane safety:**

- Crane operators are required to be adequately trained, and certified and licensed to operate said device before starting work.
- Must install guardrails and put up Warning signs at the crane working area.
- The groundwork for the hoisting operation must meet the load bearing requirements of the crane.
- Make sure that the hoisting tools have been secured to an object or wall that meets the load bearing requirements before hoisting.
- Keep the ground service staff from staying or passing under the crane boom or suspended load where the work is being carried out.
- Do not drag steel wire rope, wire rope slings, etc., and hit hoisting device with hard objects, when hoisting work is being carried out.
- Make sure that the angle between two wire ropes do not exceed 90° when hoisting.

 CAUTION!**Drilling safety:**

- Wear personal protective equipment when drilling, such as safety glasses, safety gloves, etc.
- Avoid drilling around pipes, and light switches and sockets, as the electrical wires can go horizontally and vertically around these fixtures.
- Cover the device to protect it from dusts and debris entering when drilling, and clean it at once after finishing drilling.

1.4.2 Battery Safety

 DANGER!

- Do not connect the positive and negative poles of a battery together. Or, the battery may be short-circuited. A short circuit may cause enormous amounts of current and release large quantities of energy for a short time, which may cause the battery to leak, smoke, release flammable gases, or be in thermal runaway, catch fire, or explode. Therefore, power off the battery before maintenance.
- Overheating the battery can lead to significant risks, including leakage, smoke, release of flammable gases, thermal runaway, fire, or explosion. In case of one of the following circumstances, do not install battery:
 - a. Direct sunlight
 - b. Fire source
 - c. Heater
 - d. Others conditions that can cause overheating
- Never damage the device by crushing, deforming, dropping, impacting, cutting or penetrating with a sharp object. Otherwise, it may cause a fire or leakage of electrolytes;

 DANGER!

- Never dismantle, change or damage battery, including penetrating with a sharp object, deforming, soaking in water or other liquids, to keep it away from leakage, smoke, release of flammable gases, thermal runaway, fire or explosion.
- Do not touch battery terminals with any other metal objects, which may cause heat or leak.
- Do not mix different types or makes of the battery pack. It may cause leakage or rupture, resulting in personal injury or property damage.
- The battery electrolyte is toxic and volatile. Never get contact with the leaked liquids or inhale gases in the case of the battery leakage or odor. In such a case, keep away from the battery and contact professionals immediately. Those professionals must wear PPE, such as safety glasses, safety gloves, gas masks, protective clothing, etc., power off the device, remove the battery, and contact technical engineers.
- Normally, the battery will not release any gases since it is an enclosed system. However, in the following situations: burnt, needle-pricked, squeezed, struck by lightning, overcharged, or subject to other adverse conditions that may cause battery thermal runaway, the battery may be damaged or an abnormal chemical reaction may occur inside the battery, resulting in electrolyte leakage or production of gases. To prevent fire or device corrosion, ensure that flammable gas is properly exhausted.
- Take steps to protect human beings from the gases released when burning batteries.

 WARNING!

- Install batteries in a dry area. Do not install them under areas prone to water leakage, such as air conditioner vents, ventilation vents, feeder windows of the device room, or water pipes. Ensure that no liquid enters the device to prevent faults or short circuits.
- Equip with fire-fighting device, such as dry sand, carbon dioxide fire extinguisher, etc., when installing and commissioning according to construction standards and requirements. Make sure that the above-mentioned fire-fighting device conforms to local laws, regulations and standards.
- Before unpacking, and in the process of storage and transportation, ensure that the packing cabinets are intact and the batteries are correctly placed according to the labels on the packing cabinets. Do not place a battery upside down or vertically, lay it on one side, or tilt it. Stack the batteries according to the stacking requirements on the packing cabinets. Make sure that the batteries do not fall or get damaged. Otherwise, they will need to be scrapped.
- After packing, the batteries must be correctly placed in accordance with the requirements. Do not place a battery upside down or vertically, lay it on one side, or tilt or stack it. Make sure that the batteries do not impact, fall get damaged. Otherwise, they will need to be scrapped.
- Tighten the screws on copper bars or cables to the torque specified in this document. Periodically confirm whether the screws are tightened, check for rust, corrosion, or other foreign objects, and clean them up if any. Loose screw connections will result in excessive voltage drops and batteries may catch fire when the current is high.
- After batteries are discharged, charge them in time to avoid damage due to overdischarge.

 CAUTION!

- Please read the document carefully before installation, operation and maintenance.
- Charge the battery within the specific temperature range because the low temperature may result in short circuit. Hence, do not charge the battery if the temperature is below the low limit of the operating temperature.
- Ensure that the packing cabinets are intact before unpacking. Do not use if package is damaged, and contact forwarder and manufacturer immediately.
- May leak electrolytes or release flammable gases if the battery is damaged, including dropping, crashing, bulging, or housing indentation. Do not use in the case of the above-mentioned circumstances. Please immediately contact the installer or professional operation and maintenance staff to remove or change the battery in the case of leakage of electrolytes or structural distortion. Keep the damaged battery away from other devices or inflammable and explosive materials, and ensure that non-professional personnel do not contact the damaged batteries.
- Ensure that the pungent and burning smells go away before operating.
- Do not place any objects, like tools, metal parts, etc., on top of the battery. Check and clean them up if any.
- Do not install batteries in rain, snow, fog, or other extreme weather, to prevent moisture or corrosion.
- Do not install batteries after moisturizing, transport to an isolation area, and be scrapped.
- Check if the shell of the battery is deformed or damaged before installing. If yes, do not install it.
- Check whether the positive and negative terminals of the battery are accidentally grounded. If yes, disconnect them.
- Do not weld or grind near the battery. Because an electric spark or arc may cause a fire.
- Store or recharge the battery according to the document if it is not used for a long time.
- The devices used to charge or discharge the batteries must meet the requirements of local laws, regulations, and standards.
- Power off the battery when installing and maintaining.
- Inspect the damaged battery to ensure that there is no smoke, fire, leakage of electrolytes, or heat in the period of storage.
- Do not touch the battery when it fails because of the high temperature of the surface.
- Do not step, against, or stand on the battery.
- The batteries are not allowed to be used to provide a backup power source in the following circumstances:
 - a. Medical device that is directly related to human health.
 - b. Device, like trains, elevators, etc., that may cause injuries to human beings.
 - c. Computer systems that play an important role in societies and institutions.
 - d. Nearby area with medical device.
 - e. Other devices that play a similar role, as described above.

NOTICE!

Short-circuit protection

- Use electrical tape to wrap the exposed wire outwards to prevent short circuit when installing and maintaining.
- Prevent any object from entering into batteries.

NOTICE!

In case the battery module leaks electrolyte or any other chemical materials, or gas may be generated due to the leakage of battery module, be sure to avoid contact with the discharge at all times. In case of accidentally coming into contact with them, please do as follows:

- In case of inhalation: Leave the contaminated area immediately, and seek medical attention at once;
- In case of contact with eyes: Rinse eyes with running water for 15 minutes, and seek medical attention;
- In case of contact with skin: Wash the contacted area thoroughly with soap, and seek medical attention;
- In case of ingestion: Induce vomiting, and seek medical attention.

NOTICE!

If a fire breaks out where the battery module is installed, please do as follows:

- In case the battery module is charging when the fire breaks out, provide it is safe to do so, disconnect the battery module circuit break to shut off the power charge;
- In case the device is not on fire yet, use a Class ABC fire extinguisher or a carbon dioxide extinguisher to extinguish the fire;
- If the battery module catches fire, do not try to put out the fire, and evacuate immediately.
- The battery module may catch fire when it is heated above 302°F/60°C; and in case of catching fire, it will produce noxious and poisonous gas, DO not approach and keep away.

NOTICE!

Effective ways to deal with accidents:

- In case of the damaged battery module, place it into a segregated place, and call the local fire department at the place where the user lives or qualified personnel.
- If any part of the battery module, or wiring is submerged, do stay out of the water and do not touch anything; If the battery module gets wet, don't touch it.
- If the battery module is damaged, don't use it. Otherwise, it may result in both personal injury and property damage.
- Don't use the submerged battery module again, and contact the qualified personnel

NOTICE!**Recovery of damaged or wasted battery:**

- Dispose of the damaged or wasted batteries according to local laws and regulations instead of placing them in the household trash or in curbside recycling bins. Otherwise, it may cause environmental pollution or explosions.
- Contact our company or a battery recycling company to scrap the battery, if it leaks electrolytes, or is damaged.
- Contact a battery recycling company to scrap batteries if they are expired.
- Keep the damaged or wasted batteries away from high temperatures and direct sunlight.
- Ensure that the damaged or wasted batteries are not exposed to the following environments: high humidity, corrosion.
- Do not recycle the damaged or wasted batteries for a second use, and immediately contact a battery recycling company to scrap them. Or, it may cause environmental pollution.

1.4.3 Electrical Safety

 DANGER!

- Before wiring, check that the device is intact to prevent electric shock or a fire.
- Improper operation may cause a fire, electric shock, etc.
- Prevent any objects from entering into the device when operating. Otherwise, the device may be short-circuited or damaged, the load's power supply may be derated or powered off, or personal injuries may occur.

 WARNING!

- A device required to be grounding must be grounded firstly when conducting wiring. The PNGD cable must be disconnected finally after removing any other cables.

 CAUTION!

- Do not install cables near air inlet (or outlet) of the device.

NOTICE!

- Please strictly follow the steps described in the document before installing, operating and maintaining the device. Do not modify or change the device, and adjust the installation procedure.
- Permission shall be obtained from the state or local electrical department before conducting the grid connection.
- Abide by the safety regulations stipulated by the power station.
- Mark off an operation area, install a temporary fencing or rope, and put up "No Entry" signs.
- Power off the device and shut down switches before connecting or disconnecting power cables.
- Power off the device at once and do not use again if there are any liquids entering into it.
- Check and confirm whether the tools meet the requirements described in the document before operating the device, and be registered. Check whether the number of tools is correct after installing and operating it.
- Check that the icons on the cable labels are correct before connecting power cables. Ensure that the terminals are completely covered with insulation.
- Ensure that protective shell or insulation sleeving on the electrical components are correctly installed to protect operators from electric shock.
- In the case of multiple inputs, disconnect them first; do not operate the device until it is completely powered off.
- Turn off the corresponding output switch of the power supply device while maintaining electrical terminal device and power distribution device connected to the power supply device.
- Must put up "Do Not Switch On" signs and warning signs, to prevent power connection. Do not switch on before the fault is repaired.
- Must follow the steps below if the device needs a power cut in the process of fault diagnosis and troubleshooting: power cut > electricity testing > connecting grounding cable > putting up warning signs and installing guardrails.
- Periodically check whether the screws are tightened fully.
- Only professionals can change the damaged cables.
- Do not alter, damage or obscure the logos and labels attached to the devices.
- Do not clean the internal and external parts of the device with solvents, like water, alcohol or oil.

NOTICE!**Grounding requirement:**

- The device grounding impedance shall meet the requirements of the local electrical code.
- The device shall be permanently connected to a grounding wire within the building's electrical system. Check that the device is reliably grounded.
- Do not operate the device before connecting it to the device grounding connector.
- Do not damage the device grounding connector.
- Make sure that the grounding pin in the 3 pin plug is connected to a grounding wire within the building's electrical system in the case of the 3 pin plug.
- In the case of high-current device, it shall be ensured that the protective grounding terminal of the device shell has been grounded.

NOTICE!**Wiring requirement:**

- Must abide by the local laws, regulations and standards to select, install, and route cables.
- Do not circle or twist cables. Change the power cable if the cable length is insufficient instead of joining it.
- Make sure that cables are secured and well-insulated, and meet specifications.
- Cable troughs or holes must be smooth, burr-free working surface to prevent cable damage.
- Suggest to use cable ties to bind cables to ensure that the cables inside the cabinet are tidied, and to prevent cable jacket damage. Do not circle or twist cables.
- Use fireproofing mud immediately to seal the cable holes if you need to leave for a while after finishing wiring or in the process of wiring, to prevent water vapor and small animals.
- If the external conditions (routing method, temperature, etc.) change, the cable type must be verified according to IEC-60364-5-52 or local laws, regulations and standards. For instance, verify whether the cable ampacity meets the requirements.
- The cable insulation layer may be aging, and even damaged in a high temperature environment. Therefore, at least 30 mm of distance shall be kept between the cables and heater or periphery of heat sources.
- Do as follows to prevent cables from brittle cracking due to shocking or shaking in the low temperature environment, and ensure operation safety:
 - a. Handle gently when installing cables in a low temperature environment above 0°C.
 - b. Must move the cables indoors and leave them for more than 24 hours before installing them, if the previous storage temperature is below 0°C.
- Do not throw cables to prevent damage and deteriorate performance, such as current capacity, temperature, etc.

NOTICE!

The static electricity generated by human beings can damage the static-sensitive components on the board, like large scale integrated circuit. Therefore, please follow the steps below to prevent static electricity:

- Operators must wear anti-static clothing, and anti-static gloves or wrist straps before contacting the boards, modules with exposed circuit boards, or application specific integrated circuits (ASIC). If the anti-static wrist strap is used, hook up the metal clip that's on one end to a grounded and unpainted metal surface.
- Hold the circuit board or the modules with exposed circuit board by its edges without components. Do not contact the components.
- Use anti-static materials to pack the removed boards or modules before storage or transportation.

1.5 Safety Instructions of PV, Inverter and Grid

Save these important safety instructions. Failure to do so may result in damage to the inverter and injury or even loss of life.

1.5.1 Safety Instructions of PV

 **DANGER!**

Potential risk of lethal electrical shock associated with the photovoltaic (PV) system

- Exposure to sunlight can result in the generation of high DC voltage by PV modules, which can lead to electric shock causing severe injuries or even death.
- Never touch the positive or negative poles of the PV connecting device, and avoid touching both poles simultaneously.
- Do not ground the positive or negative poles of the PV modules.
- Only qualified personnel can perform the wiring of the PV modules.

 **WARNING!**

- Overvoltage protection with surge arresters should be provided when the PV system is installed. The grid connected inverter is fitted with SPDs on both PV input side and MAINS side.
- Please consult professionals before installing SPDs.

 **WARNING!**

- Make sure that the input DC voltage does not exceed the maximum DC input voltage specified for the inverter. Overvoltage can cause irreversible damage to the inverter, and such damage is not covered by the warranty.
- PV modules should have an IEC61730 class A rating.

1.5.2 Safety Instructions of Inverter

DANGER!

Potential risk of lethal electrical shock associated with the inverter

- Only operate the inverter if it is in a technically faultless condition. Operating a faulty inverter may lead to electric shock or fire.
- Do not attempt to open the enclosure without authorization from SolaX. Unauthorized opening of the enclosure will void the warranty and can result in lethal danger or serious injury due to electric shock.
- Make sure that the inverter is reliably grounded before any operation to prevent the risk of electric shock causing lethal danger or serious injury.
- Only qualified personnel can perform the installation, wiring, maintenance of the inverter by following this document and the related regulations.

DANGER!

- Prior to any wiring connection, establishing an earth connection is essential.

WARNING!

- During operation, avoid touching any parts of the inverter other than the DC switch and LCD panel.
- Never connect or disconnect the AC and DC connector while the inverter is running.
- Prior to conducting any maintenance, turn off the AC and DC power and disconnect them from the inverter. Wait for 5 minutes to fully discharge the energy.

WARNING!

Potential danger of scalding due to the hot enclosure of the inverter

- Avoid touching the inverter while it is running, as it becomes hot during operation and may cause personal injuries.

WARNING!

- When handling the battery, carefully follow all safety instructions provided in the battery manual. The battery used with the inverter must meet the specified requirements of the series inverter.

CAUTION!

- Make sure that children are supervised to prevent them from playing with the inverter.
- Pay attention to the weight of the inverter and handle it properly to avoid personal injuries.
- Use insulated tools when installing the device, and always wear personal protective equipment during installation and maintenance.

NOTICE!

- The inverter has an integrated Type-B Residual Current Monitoring Unit (RCMU). If an external Residual Current Device (RCD) is required by local regulations, verify the type of RCD required. It is recommended to use a Type-A RCD with a rating of 300 mA unless a lower value is required by the specific local electric codes. When required by local regulations, the use of an RCD type B is permitted.
- Keep all product labels and the nameplate on the inverter clearly visible and well-maintained.

1.5.3 Safety Instructions of Utility Grid

NOTICE!

- Only connect the inverter to the grid with the permission of the local utility grid company.

2 Routine Maintenance

2.1 Preparations Before Maintenance

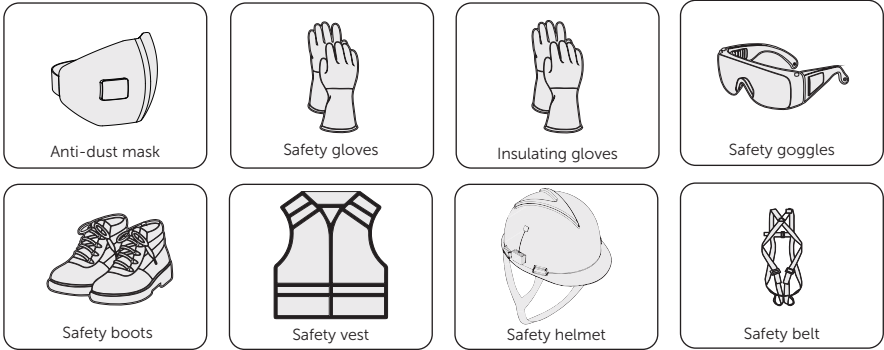

* This section only lists protective equipment, please refer to the appropriate section for specific replacement tools.

2.2 Routine Maintenance

Regular maintenance is required for the device. Please follow the instructions below to inspect and maintain the system. More frequent maintenance service is needed in the worse work environment. Please make records of the maintenance.

Prerequisites

- Tools: Cross screwdriver, torque wrench, ladder.

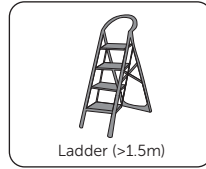
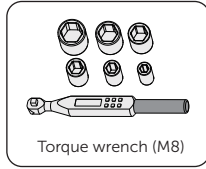
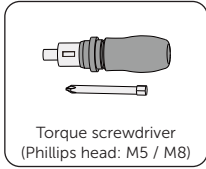

Procedure

Step 1: Patrol the system round, checking the following items in turn:

Check item	Description	Interval time
System appearance	Check whether there is any damage to the distributed energy system, and the equipment is deformed.	Every 6 months
Operating status	Check whether there is any abnormal noise or odour in the running system.	Every 6 months
Cabinet ventilation	Check whether the mesh on the front door are ventilated properly and are not blocked by dust and leaves.	Every 6 months

Step 2: View alarms on the cabinet screen, for details, see “3.1 Cabinet Screen”.

Step 3: System power off, for details of the power off procedure, see “2.3 Power Off”.

Step 4: Open the cabinet door, checking the following items:

NOTICE!

- Please gently open the door to prevent raising dust from the filter cotton. Otherwise, the smoke detector will alarm and give a command to the automatic fire sprinkler to spray gas.

Check item	Description	Interval time
Cabinet internal environment	<ul style="list-style-type: none"> • Check whether there is any obvious debris inside the cabinet, if so, please make cleaning. • Check whether there is water in the cabinet. 	Every 6 months

Check item	Description	Interval time
Parts appearance	Check the appearance of the inverter, battery packs, air conditioner, smoke detector, temperature sensor, toxic gases detector, UPS, EMS, I/O module and distribution box for damage or deformation.	Every 6 months
Aerosol	Check the appearance of the aerosol: no deformation and nozzle integrity, confirm no agent leakage	Every 6 months
Antennae	Check whether the antenna is rusty due to salt spray, if so, the antenna needs to be replaced.	Every 6 months
Electrical connection	<ul style="list-style-type: none"> • Check the electrical connection of battery packs, inverter, distribution box and EMS for looseness and cable jacket damage, especially the cable jacket connecting with the metal parts. • Check whether the sealing caps on idle terminals of inverter are and not falling off. • Check whether the electrical insulation tape is in good condition and no peeling. • Check whether there is any fading to the screws and copper bars. 	Every 6 months

Step 5: System power on, for details of the power on procedure, see “2.4 Power On”.

Step 6: Open the cabinet door, checking the following items:

Check item	Description	Interval time
Parts operating status	<ul style="list-style-type: none"> • Check whether there is any abnormal noise when the inverter, battery packs, distribution box, air conditioner and UPS are in operation. • Check whether the indicator of distribution box, EMS and I/O module lights normally. 	Every 6 months
Safety function	<ul style="list-style-type: none"> • Check whether the emergency stop button and LED is in good working condition. • Check the stopping signal and communication by simulating the shutdown operation. • Check whether there are any damages to warning signs and other labels pasted on the equipment. If so, please replace them in time. 	Every 6 months

2.3 Power Off

Check whether the system is still running before power off. Do not power off if the device is "under load".

Regarding the detailed location of the modules in the cabinet, please refer to Figure 2-1.

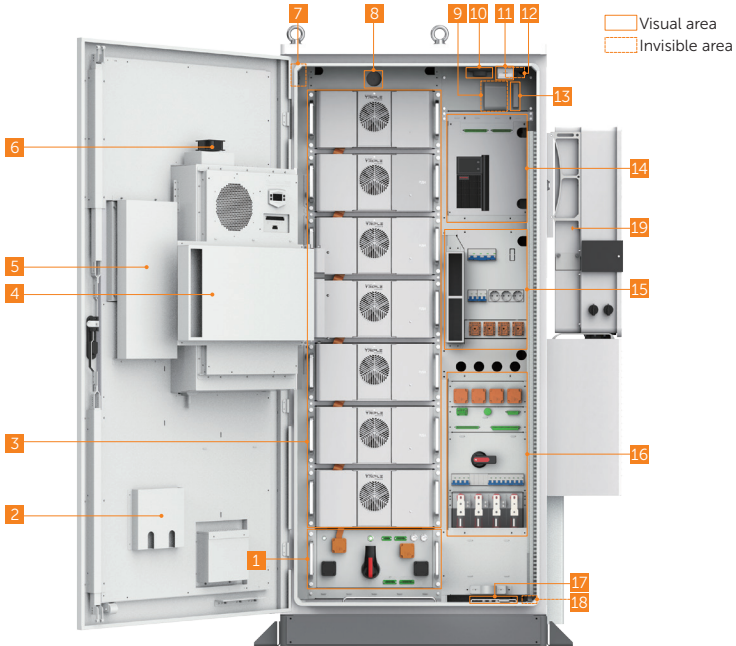

Figure 2-1 Parts description (in the opened state)

Table 2-1 Parts description

No.	Item	Description
1	High-voltage box	To collect current and voltage information on battery tower, ad control the charge and discharge of battery pack.
2	File pocket	To put documents.
3	Battery pack	/
4	Wind baffle	To provide a channel of air to flow.
5	Display screen cover	To protect display screen.
6	Fan	To improve air circulation and dissipate heat when the temperature rises.

No.	Item	Description
7	Temperature and humidity sensor	To measure temperature and humidity.
8	Automatic fire sprinkler	To control or suppress the spread of fire
9	Audible and visible alarm	To alert you when the abnormal conditions occur, such as temperature, smoke.
10	Smoke detector	To detect smoke.
11	Door sensor	To alert you when the door is open.
12	Temperature sensor	To detect temperature.
13	Toxic gases detector	To detect toxic gases.
14	Control area	Including IO module, EMS, UPS, etc.
15	EPS area	/
16	Distribution box	To distribute AC power for the energy storage system.
17	Grounding bar	To provide a physical connection to the earth, and to be used to dissipate current.
18	Water sensor	To detect water level based on the principle of potential difference between the two electrodes.
19	Inverter	SolaX's X3-AELIO series inverter which is not delivered with the cabinet.

Step 1: Open the door.

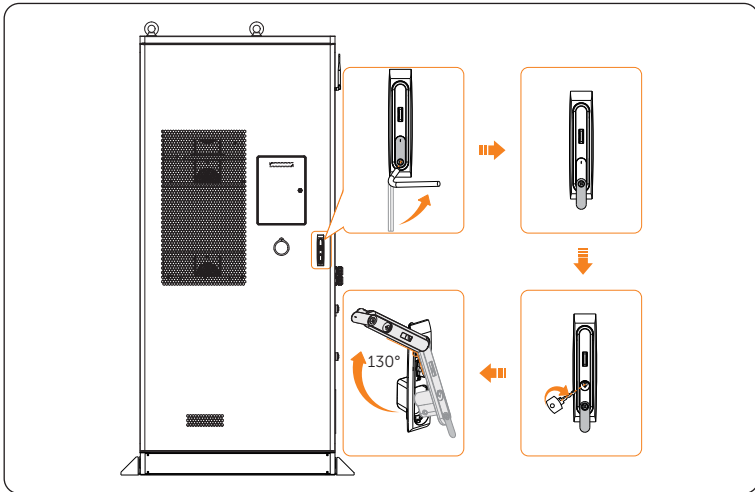

Figure 2-2 Opening the door

Step 2: Inverter power off.

- a. Set **OFF** in the **System ON/OFF** on the inverter LCD screen.
- b. Turn off the inverter system button.
- c. Set the DC switch1 and DC switch2 to "OFF".

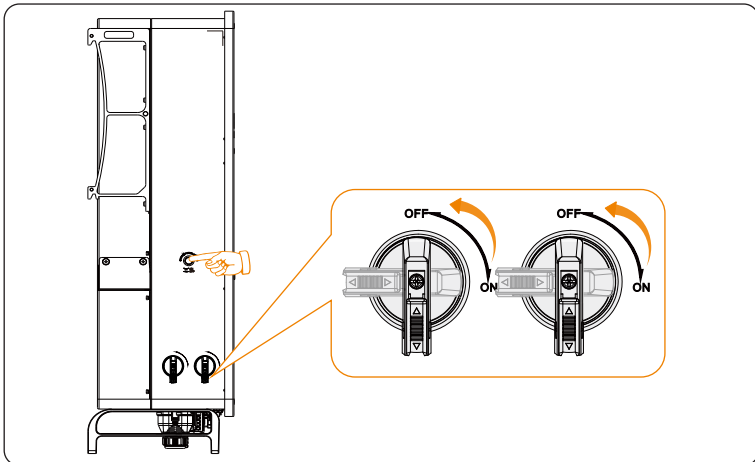

Figure 2-3 Shutting down the inverter

Step 1: Perform operations on the EPS area.

- » Flip down EPS breaker;
- » Flip down "breaker for maintenance (APS2)";
- » Flip down "UPS breaker (UPS)".

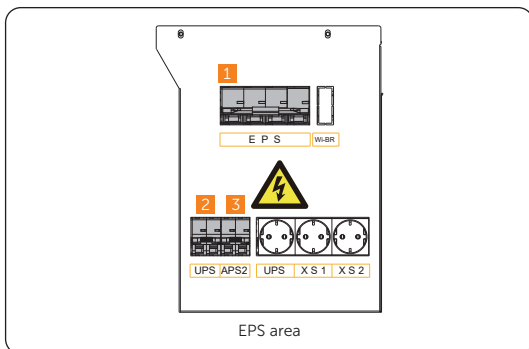

Figure 2-4 Performing on EPS area

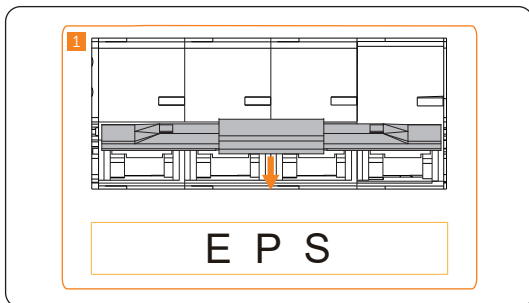

Figure 2-5 Flipping down EPS breaker

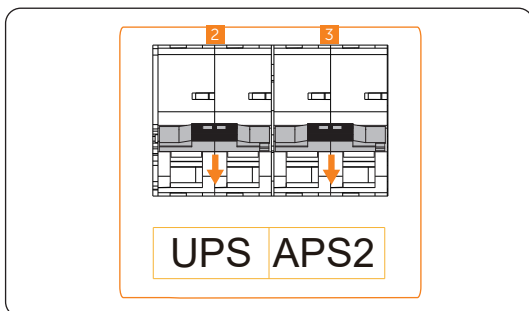

Figure 2-6 Flipping down UPS and APS2 breaker

Step 2: Gently press the power button, and rotate the disconnecter of the high-voltage box to "OFF".

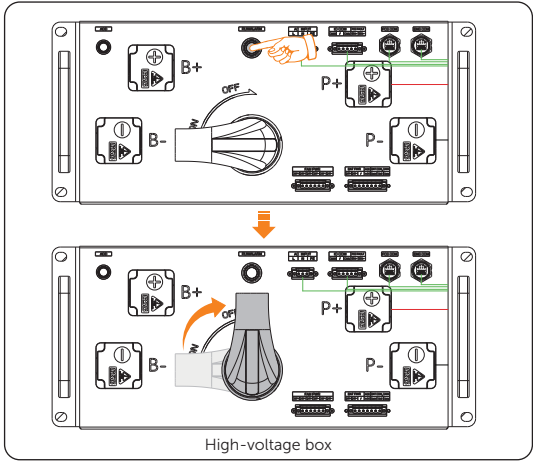

Figure 2-7 Shutting down the high-voltage box

Step 3: Hold and press the "Power on/off" button to power off the UPS.

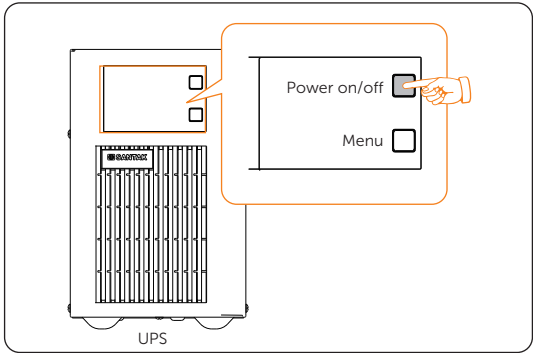

Figure 2-8 Holding and pressing button

Step 4: Shut down the distribution box.

- » Flip down the "auxiliary power breaker of high-voltage box (APS1)";
- » Flip down the "lightning protection breaker (SPD MCB)";
- » Flip down the "air conditioner/liquid cooling unit on/off breaker (HVAC MCB)";
- » Flip down the "reserve breaker (RES)";
- » Rotate the switch on the distribution box 90° counter-clockwise to "OFF".

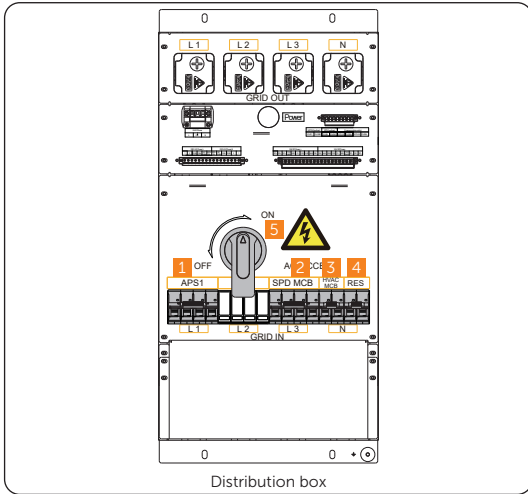

Figure 2-9 Shutting down sequence of distribution box

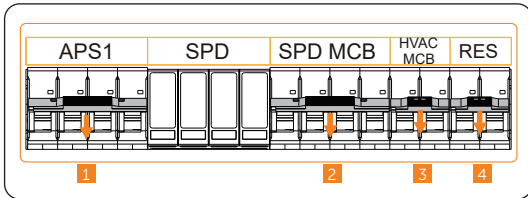

Figure 2-10 Flipping down breakers

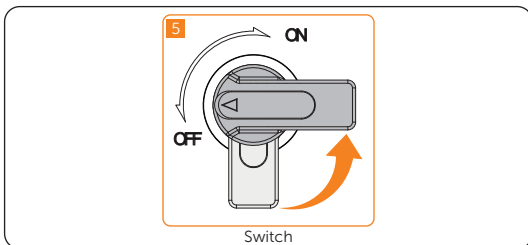

Figure 2-11 Rotating switch

WARNING!

- The device may still have power and heat after turning off, which may cause electric shock and personal injuries. Therefore, please allow it to cool for at least 5 minutes and wear PPE before conducting maintenance.

Emergency Power Off

WARNING!

- Do not press the emergency stop button except for emergencies.
- Some modules inside the cabinet may still have power after pressing the emergency stop button, therefore, non-professionals are not allowed to operate them.

Step 1: Rotate the cover

Step 2: Press the emergency stop button.

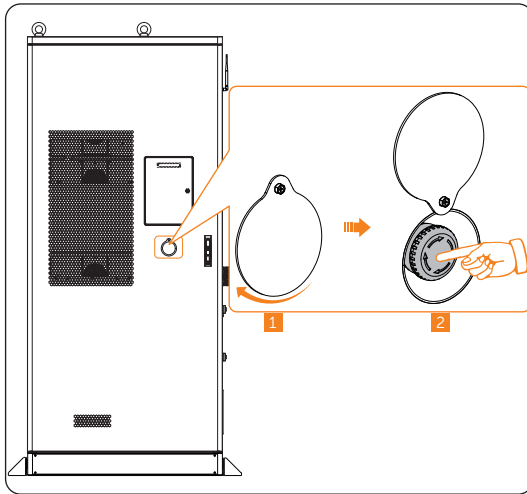

Figure 2-12 Pressing emergency stop button

NOTICE!

If it has been pressed, the emergency stop button must be reset before starting the equipment. The reset steps are shown as follows:

- a. Rotate the cover;
- b. Rotate the button according to the arrow direction shown on the button. Then the button will spring back to its original position.

2.4 Power On

Checking before power on

Ensure that all the cables connecting to the EPS and distribution box (grid side) are wired and securely fastened. For details, please refer to the following table.

Table 2-2 Checklist

No.	Item	Description
1	Equipment appearance	<ul style="list-style-type: none"> • Check the equipment is in good condition, with a clean, non-peeling paint, and rust-free surface. • Ensure that the labels on the equipment are clear and easy to read. If it is damaged, the label shall be replaced at once.
2	Installation	<ul style="list-style-type: none"> • The battery cabinet, inverter and other device (if any) are installed correctly and securely. • All the screws are tightened.
3	Cable appearance	<ul style="list-style-type: none"> • Check that the cable jacket is in good condition. • Check that the protective pipes are in good condition.
4	Cable connection	<ul style="list-style-type: none"> • Check that the cable connection position is consistent with the design principles. • Ensure that the procedure for crimping terminals strictly observe the requirements, and the terminals are securely fastened. • Check that the labels on the both sides of cables are clear, and the direction of both labels is the same. • Check that all DC, AC cables, ground cable, communication cables and meter/CT of the inverter are connected correctly and securely • Check that the external AC and DC connectors are connected; The connectors on the Grid and EPS terminal are connected correctly and securely. • Check the unused terminals and ports of the inverter are locked by waterproof caps. • Check that all photovoltaic panels are connected correctly and securely.

No.	Item	Description
5	Wiring	<ul style="list-style-type: none"> • Ensure that the wiring procedure is consistent with the principle of separation of strong and weak electricity. • Ensure that the cables are neatly places. • Leave a little extra length for adjustments. • Keep cables tidy in the cabinet. • Check if the grid connection voltage meets: L1+N=220/230 V, L2+N=220/230 V, L3+N=220/230 V, L1+L2=380 V, L2+L3=380 V, L1+L3=380 V.
6	Copper bars in the battery pack	<ul style="list-style-type: none"> • Check to make sure the copper bars are not deformed.
7	Button/Switch	<ul style="list-style-type: none"> • Check the distribution box's switch is "OFF". • Check the battery packs' switches are "OFF". • All the DC breakers and AC breakers are "OFF"

Power on procedure

Regarding the detailed location of the modules in the cabinet, please refer to .

NOTICE!
<ul style="list-style-type: none"> • Please check that the emergency stop button remains in the closed position before powering on.

NOTICE!
<ul style="list-style-type: none"> • Please check that the emergency stop button remains in the closed position before powering on.

Step 1: Start the distribution box.

- » Rotate the switch on the distribution box 90° clockwise to "ON";
- » Flip up the "auxiliary power breaker of high-voltage box (APS1)";
- » Flip up the "lightning protection breaker (SPD MCB)";
- » Flip up the "air conditioner/liquid cooling unit on/off breaker (HVAC MCB)";
- » Flip up the "reserve breaker (RES)".

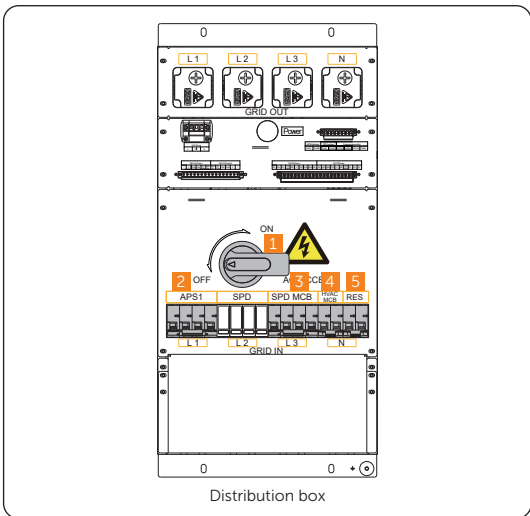

Figure 2-1 Starting sequence of distribution box

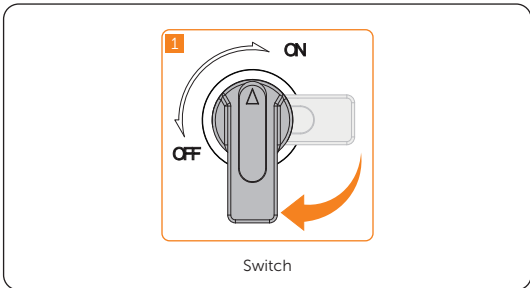

Figure 2-2 Rotating switch

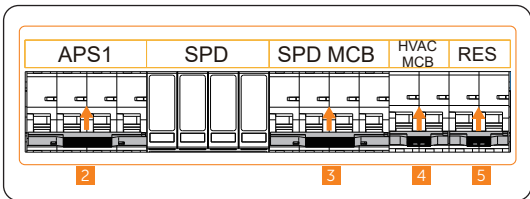

Figure 2-3 Flipping up breakers

Step 2: Start the inverter.

- a. Switch on the inverter DC switch and check the LCD screen, check the PV voltage.
 - » If the PV voltage is 0, turn off the DC switch, pull out the PV connectors and then measure the voltage of the positive and negative PV port (in MPPT voltage range 160-950 V) or check whether the positive and negative poles of PV cables are reversed.
- b. Press and turn on the inverter system button.

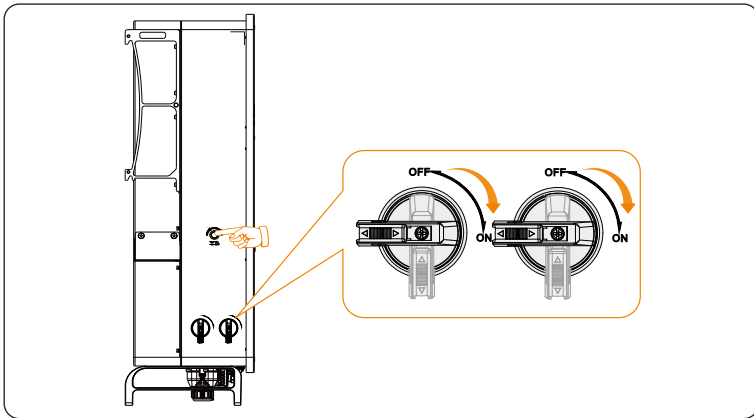

Figure 2-4 Starting the inverter

- c. Set **System ON/OFF** as ON status on the inverter screen, and the LCD displays waiting status.
- d. When the photovoltaic panels generate enough power or the battery supplies power, the inverter will start automatically. The inverter will go Waiting, Checking and Normal status in sequence.
- e. Check whether the meter/CT is correctly connected.
 - » If CT is connected, please perform the Meter/CT Check to check the correct connection through the setting path: **Menu>Setting>Advance Setting>Meter/CT Settings>Meter/CT Check**
 - » If meter is connected, please set the connection of Meter through the setting path: **Menu>Setting>Advance Setting>Meter/CT Settings.**

NOTICE!

- When the meter or CT is correctly connected, the meter/CT power displays on the METER/CT check interface; when the connection method is wrong, **Meter Fault** displays on this interface.

Step 3: Perform operations on the EPS area.

- » Flip up EPS breaker;
- » Flip up "breaker for maintenance (APS2)";
- » Flip up "UPS breaker (UPS)".

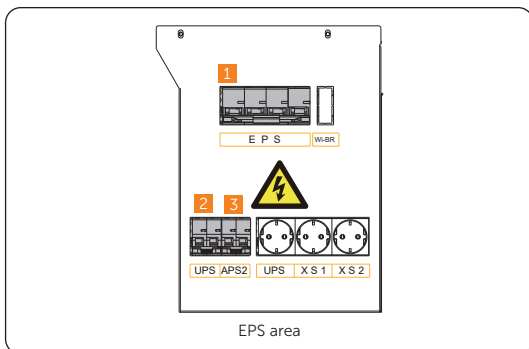

Figure 2-5 Performing on EPS area

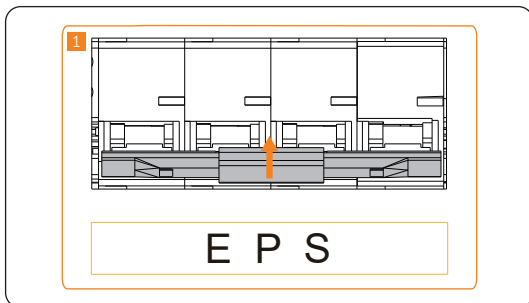

Figure 2-6 Flipping up EPS breaker

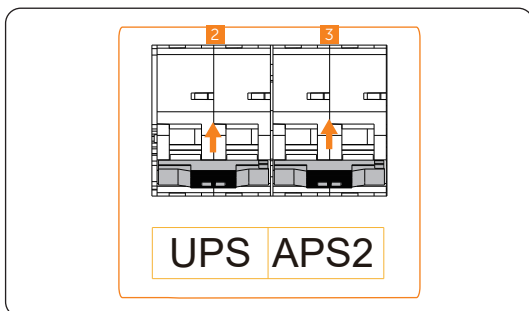

Figure 2-7 Flipping up UPS and APS2 breaker

Step 4: The startup sound on boot will be heard when holding and pressing the "Power on/off" button to start the UPS.

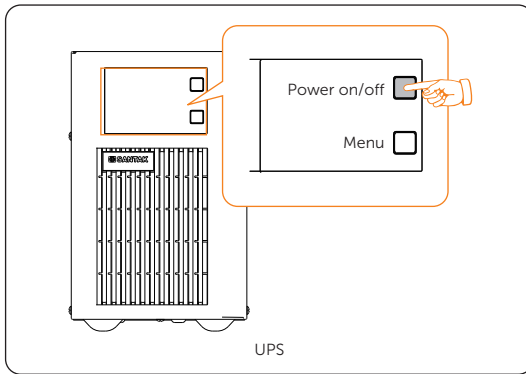

Figure 2-8 Holding and pressing button

Step 5: Rotate the disconnecter of the high-voltage box to "ON", and then gently press the power button. At the point, the LED light will come on green.

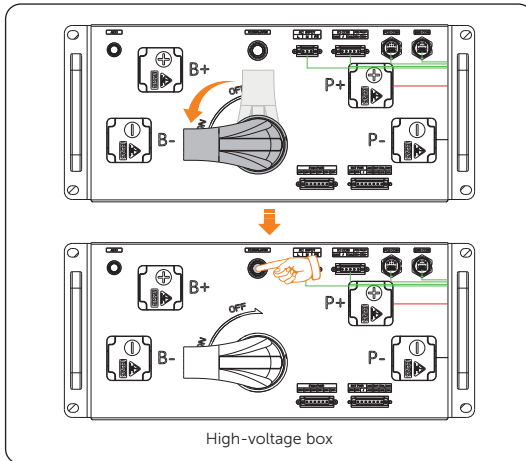

Figure 2-9 Starting the high-voltage box

Step 6: Close the door after the equipment has been started.

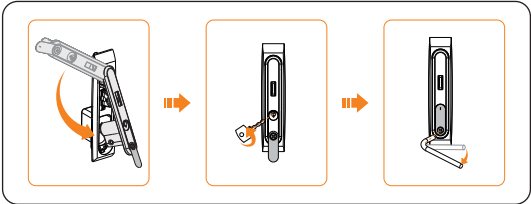

Figure 2-10 Closing the door

NOTICE!

- Please properly keep the key.

Checking after power on

- a. Check whether the system has any abnormal noise.
- b. Check whether the indicator lights report an error and check the system for alarm through the cabinet screen
- c. Check the running status of the system through the cabinet screen.

3 Alarm Reference

System alarms can be viewed through the following channels: cabinet screen, ESM1000 webpage, SolaxCloud APP, please handle alarms according to the suggestions. If you are unable to view the alarm information, please check the *AELIO-P50B100 and AELIO-P60B100 Troubleshooting Manual*.

3.1 Cabinet Screen

3.1.1 Logging in

Gently and correctly guide the key into the keyhole, and then turn it clockwise to unlock the screen door.

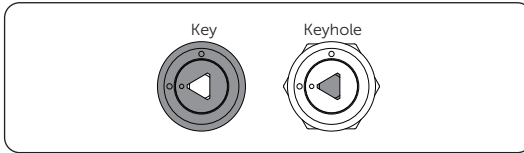

Figure 3-11 Correct position

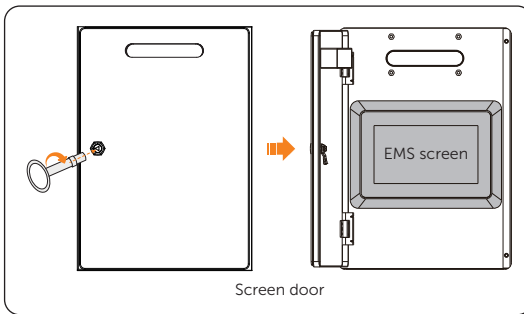

Figure 3-12 Unlocking screen door

On the login screen, enter the username and password, and then tap **Login**.

Admin and user accounts are supported.

Table 3-1 Account information

Username	Password	Remarks
Admin	EMS SN	The password cannot be modified
User	123456 by default	The password can be modified on EMS1000 webpage.

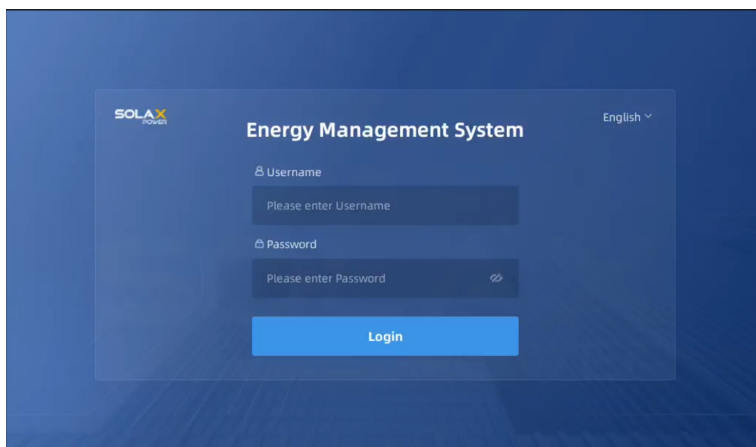

Figure 3-1 Logging in to the screen

3.1.2 Viewing Alarms

Alarm information includes the device name and type, error code, alarm name, alarm level, time that the alarm occurs and stops, alarm status and more.

Log in to the webpage, and then select **Alarm**.

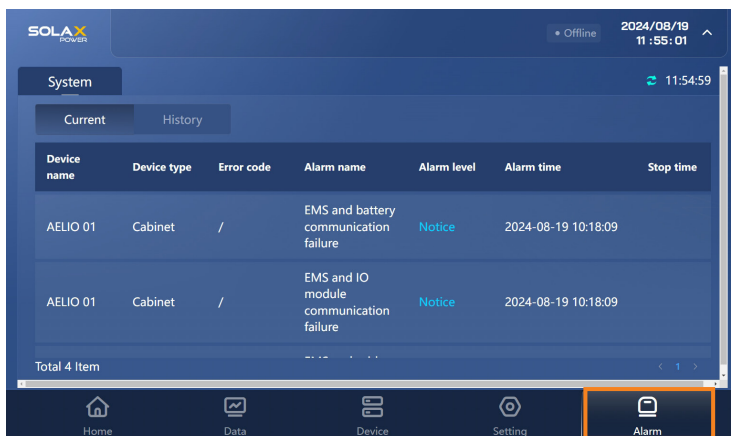

Figure 3-1 Logging in to the screen

Table 3-2 Alarm information description

Parameter	Description
Device name	Brief description of the device
Device type	The device with which the alarm occurs
Error code	Only available for inverter errors
Alarm name	Brief description of the alarm
Alarm level	Emergency urgency level of the alarm, divided into critical, warning and notice
Alarm time	Time that the alarm occurs
Stop time	Time that the alarm is resolved
Operation	Click Detail to view to view more details on the alarm.

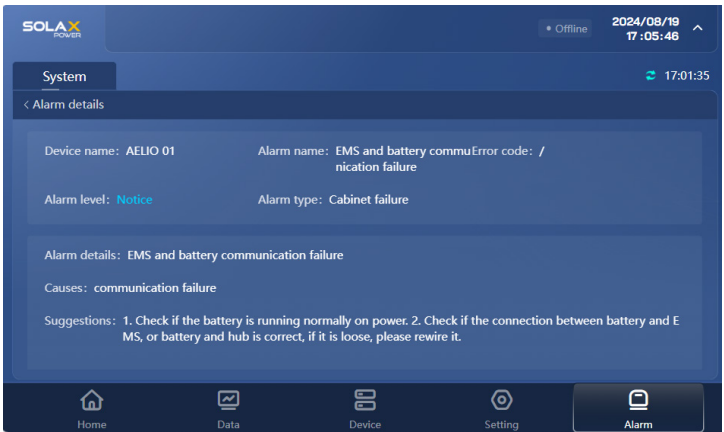

Figure 3-2 Alarm details

3.2 EMS1000 Webpage

NOTICE!

Screenshots of V002.05 software are used for example in this chapter, and the actual page details might vary.

3.2.1 Logging in

NOTICE!

IE browser is not supported currently, and we recommend logging in to the webpage through Chrome.

Step 1: Connect the computer to NET2 of EMS1000 with a network cable, or connect the computer to EMS1000 hotspot named WiFi_SN, and then go to the defined IP address based on the connection mode.

- » For wired connection: 192.168.11.10
- » For hotspot connection: 192.168.10.10

Step 2: On the login page, select the language, enter the username and password, and then click **Login**.

The default username and password for the user account are user and 123456.

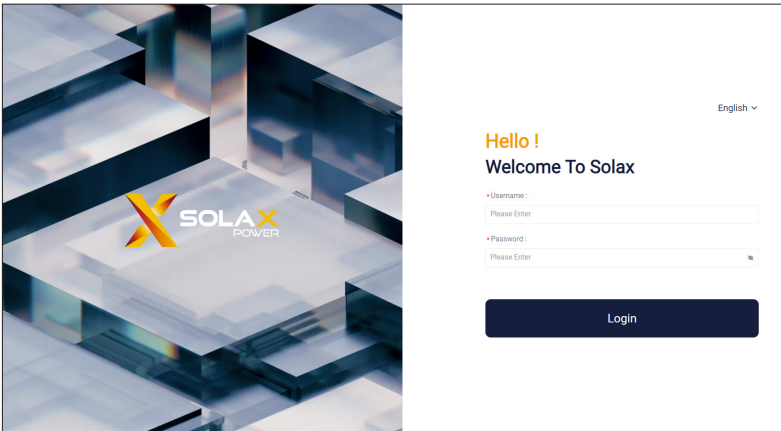

Figure 3-1 Login page

3.2.2 Viewing Alarms

Alarm information includes the device type and SN, alarm name, error code, alarm level, time that the alarm occurs and ends, alarm status and more.

Log in to the webpage, and then select **Alarm info**.

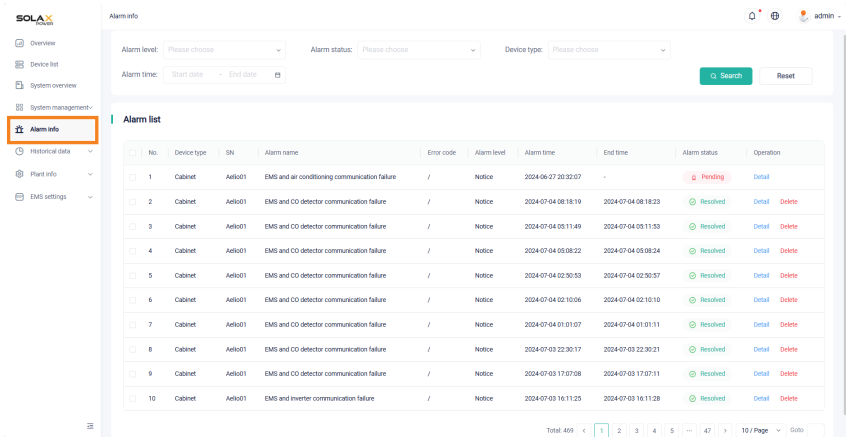

Figure 3-2 Viewing alarm information

Table 3-3 Alarm information description

Parameter	Description
Device type	The device with which the alarm occurs
SN	SN of the alarm device
Alarm name	Brief description of the alarm
Error code	Only available for inverter errors
Alarm level	Emergency urgency level of the alarm, divided into critical, warning and notice
Alarm time	Time that the alarm occurs
End time	Time that the alarm is resolved
Alarm status	<ul style="list-style-type: none"> Pending: Alarms that are not resolved yet Resolved: Alarms that have been resolved

You can click **Detail** under **Operation** on each alarm to view more details on the alarm, and the possible causes and suggestions that we offer for each type of alarm. This helps you to solve the problem quickly and efficiently.

Alarm details x

Device model AELIO-P50B100	Alarm type Cabinet failure
-------------------------------	-------------------------------

Alarm details:
EMS and CO detector communication failure

Causes:
communication failure

Suggestions:

1. Check if the connection between RS-485-2(A2, B2) of IO module and CO sensor is correct, if it is loose, please rewire it. Then check whether the communication of the device is normal through EMS or cloud after wiring.
2. Check if the CO sensor is supplied with power, if not, please rewire it.
3. Check if the communication line of the CO sensor is normal. PIN terminal 1,4 is to 485A and PIN terminal 2,5 for 485B. (24V+ for PIN terminal 3, 24V- for PIN terminal 8). If it is not working properly, please connect the wires again.

Colors: PIN terminal 1: orange white; PIN terminal 2: orange; PIN terminal 3: green white; PIN terminal 4: blue; PIN terminal 5: blue white, PIN terminal 8: brown

Figure 3-3 Alarm details

3.3 SolaX Cloud App

3.3.1 Downloading and Installing App

Select and scan the QR code below to download SolaxCloud APP. You can also find the QR codes at the top left of the login page of www.solaxcloud.com or on the user manual of Pocket series communication module. In addition, you can search with the key word SolaxCloud in Apple Store or Google Play to download it.



Figure 3-1 QR code

Please watch the video or read the document on the SolaXCloud App for relevant operation.

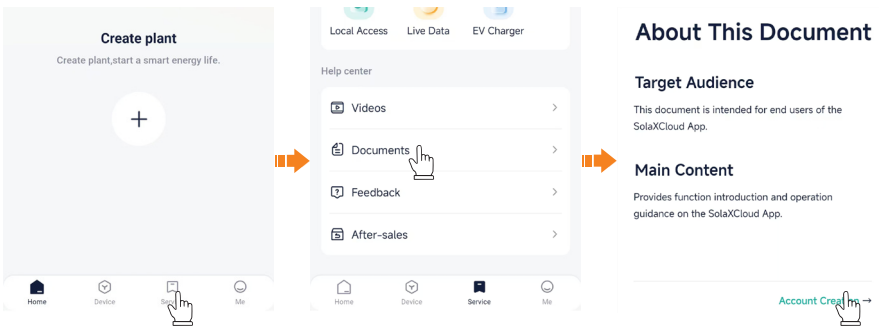

Figure 3-2 App guide on SolaXCloud

Please follow the steps below to view alarm information.

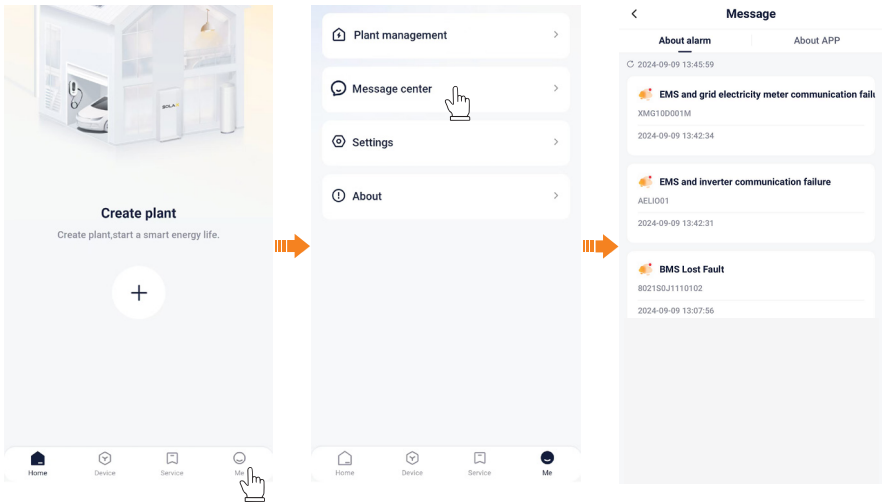

Figure 3-3 Viewing alarm information

NOTICE!

- The screenshots in this chapter correspond to the SolaX Cloud App V6.2.0.

4 Replacement of Battery Pack

Prerequisites

- Fault locating:
 - a. View alarm information via cabinet screen, EMS1000 webpage, SolaXCloud App or troubleshooting manual.
 - b. Refer to the alarm handling suggestions in the alarm details.
 - c. Contact Solax and order replacement parts.
- Tools: Cross screwdriver, torque wrench, electric forklift, ladder.

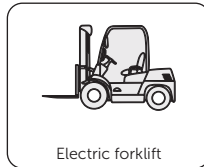
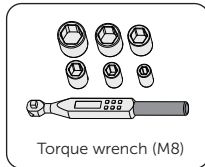
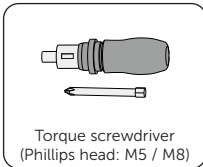

- At least four persons are required to replace the component.

DANGER!

- Do not disassemble the battery violently. Otherwise, it may lead to battery pack short circuit, damage to the device (leakage, rupture), fire or explosion.

WARNING!

- Before replacing the battery pack, ensure that the system is powered off. Otherwise, electric shocks may occur.
- After the system powers off, there will still be the remaining electricity and heat which may cause electric shocks and body burns. Please wear personal protective equipment (PPE) and begin servicing the system five minutes after power off.
- Only qualified person can perform the maintenance for the device.

 **WARNING!**

- Before transportation, check that the battery package is intact and that there is no abnormal odor, leakage, smoke, or sign of burning. Otherwise, the batteries cannot be transported.
- Handle gently when moving the battery pack to prevent bumping or damage.
- Before moving a faulty battery pack (with scorch, leakage, bulge, or water intrusion), insulate its positive and negative terminals, pack it, and place it in an insulated explosion-proof box as soon as possible. Record information such as the site name, address, time, and fault symptom on the box.
- Keep away from flammable material storage area, residential areas, and other population centers (e.g., public transport, elevators) when transporting the faulty battery pack.

 **WARNING!**

- Before unpacking the battery, check whether the package is intact, batteries with damaged packaging should not be used, please notify the transporter and the manufacturer immediately if it is damaged.
- Before installing the battery pack, inspect the battery pack shell for deformation or damage.
- After removing the package from the battery pack, the installation must be completed within 24 hours, if it cannot be installed in time, the battery needs to be repacked and placed in an indoor, dry, non-corrosive gas environment; after completing the installation of the energy storage system, it must be powered on within 24 hours; the unpacking of the batteries to the powering on of the energy storage system needs to be completed within 72 hours, and the power off time can not be more than 24 hours for the later regular routine maintenance.

NOTICE!

- The expenses for dispose of the wasted or damaged battery packs incurred shall be borne by the user.

NOTICE!

- The replaced devices should be sent back to the local Solax warehouse.

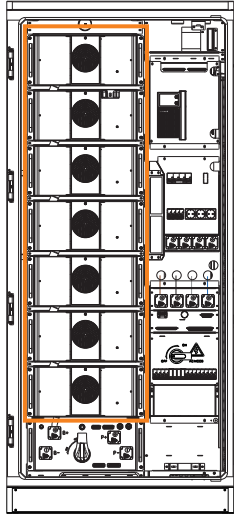

Figure 4-1 Position of the battery packs

Procedure

NOTICE!

- This section takes the replacement of battery pack 4 as an example.

Step 1: Press to open the covers on both sides of the battery pack to be replaced and the adjacent battery packs.

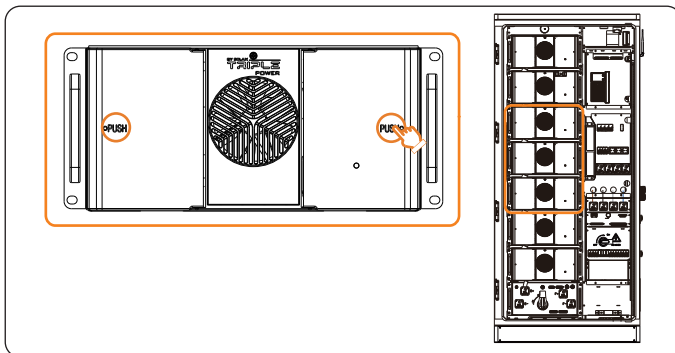

Figure 4-2 Opening the battery pack cover

Step 2: Remove the copper bars and cables.

1. Remove the covers of the copper bars.
2. Unscrew the screws and remove the negative copper bar, snap the copper bar covers.
3. Unscrew the screws and remove the positive copper bar, snap the copper bar covers.
4. Remove the cables of the BMU.

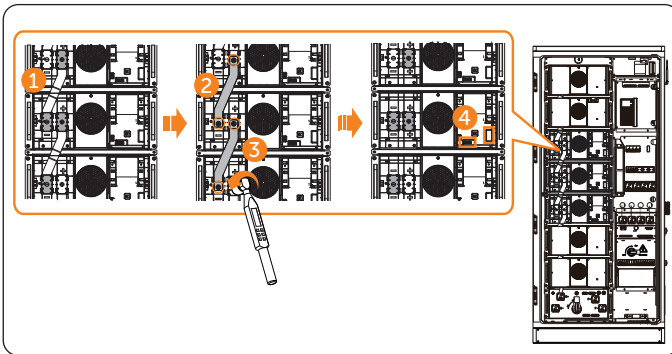

Figure 4-3 Removing the copper bars and cables

! WARNING!

- After removing the copper bars, it is necessary to install the covers back, otherwise electric shock may occur.

Step 3: Unscrew the M5 screws on the baffle, remove the baffle. Unscrew the M8 screws on the battery pack.

Figure 4-4 Removing the baffle

- Step 4:** Draw the battery pack onto a forklift and transport it with the forklift.
- Step 5:** Transport the new battery packs to the designated location with a forklift and manually push the battery packs into the cabinet. Secure the battery pack with M8 screws. Install the baffle and secure with M5 screws.

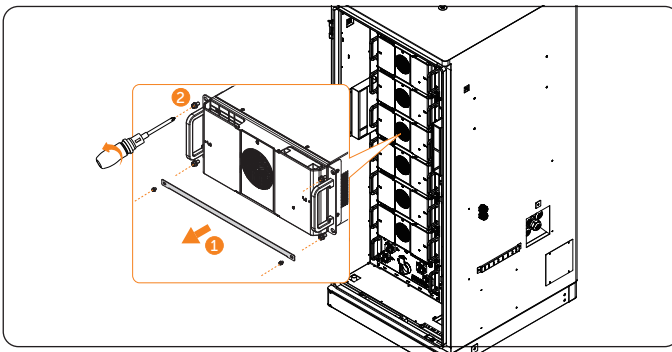
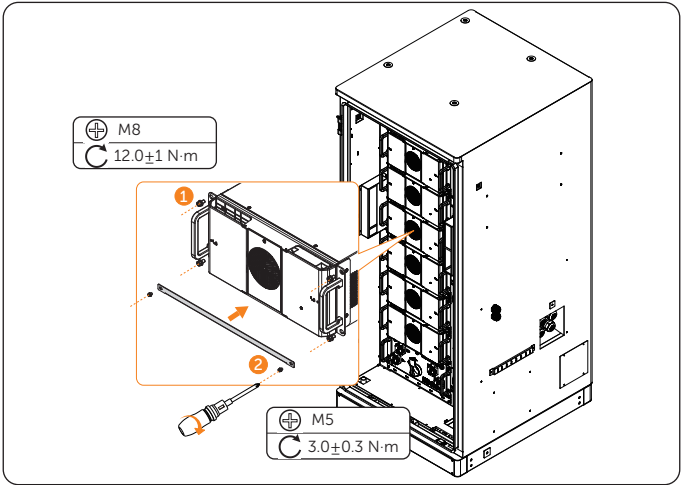

Figure 4-5 Installing the battery pack

- Step 6:** Install the copper bars and cables.
 1. Remove the covers of the copper bars.
 2. Install the negative copper bars, snap the copper bar covers.
 3. Install the positive copper bars, snap the copper bar covers.
 4. Connect the cables of the BMU.

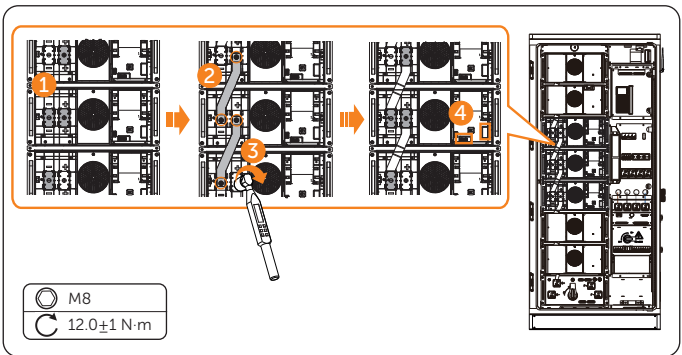

Figure 4-6 Installing the copper bars and cables

Step 7: Long press the button of the high-voltage box for 10 seconds for address assignment.

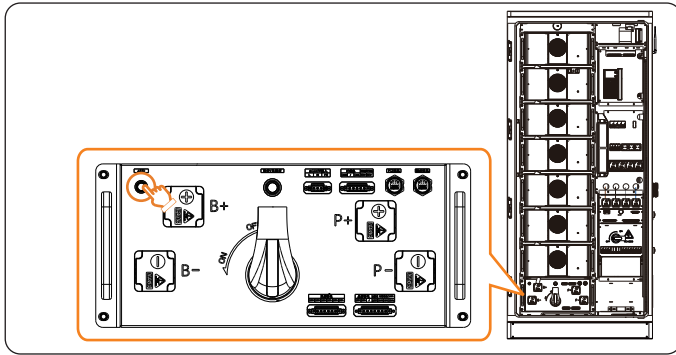

Figure 4-7 Address assignment

Checking after replacement

Step 1: Power on the system. For details, refer to “2.4 Power On”.

Step 2: Check whether the functions are restored.

No.	Check Item	Criteria
1	Alarm information	The alarm status is displayed as resolved and no new alarms are generated
2	Function	The communication and charging/discharging functions are normal.
3	Running data	<ul style="list-style-type: none"> • Number of modules: 16 • Module voltage range: 43.2-58 V • Cell voltage range: 2.5-3.65 V • Module temperature range: -20°C to +53°C • Charging cutoff SOC for the ESR: Set it to 90% first, and then adjust it to 100% after the system balancing is complete.
4	Appearance	<ul style="list-style-type: none"> • There is no obvious damage to the appearance. • There is no obvious paint peeling or rust. • The screws are secured. • The fans rotate properly without abnormal sound. • The front panel vent is clean and free from blockage.

5 Replacement of Battery Pack Fan

Prerequisites

- Fault locating:
 - a. View alarm information via cabinet screen, EMS1000 webpage, SolaXCloud App or troubleshooting manual.
 - b. Refer to the alarm handling suggestions in the alarm details.
 - c. Contact Solax and order replacement parts.
- Tools: Cross screwdriver, ladder.

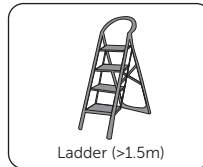
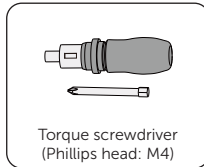

DANGER!

- Do not disassemble the battery violently. Otherwise, it may lead to battery pack short circuit, damage to the device (leakage, rupture), fire, or explosion.

WARNING!

- Before replacing the battery pack fan, ensure that the system is powered off. Otherwise, electric shocks may occur.
- After the system powers off, there will still be the remaining electricity and heat which may cause electric shocks and body burns. Please wear personal protective equipment (PPE) and begin servicing the system five minutes after power off.
- Only qualified person can perform the maintenance for the device.

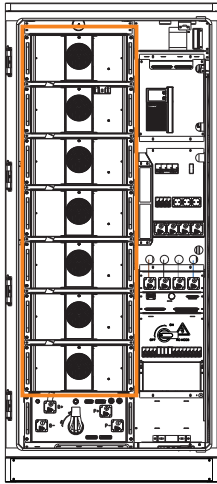

Figure 5-1 Position of the battery pack fans

Procedure

Step 1: Press to open the cover of the battery pack.

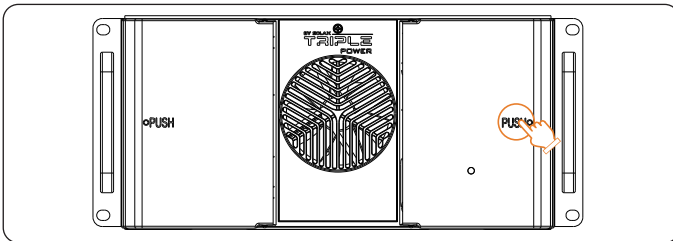

Figure 5-2 Opening the battery pack cover

Step 2: Remove the cable of the fan.

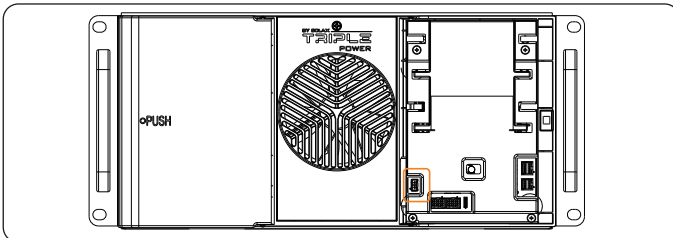

Figure 5-3 Removing the cable

Step 3: Unscrew the screw on the cover, remove the cover.

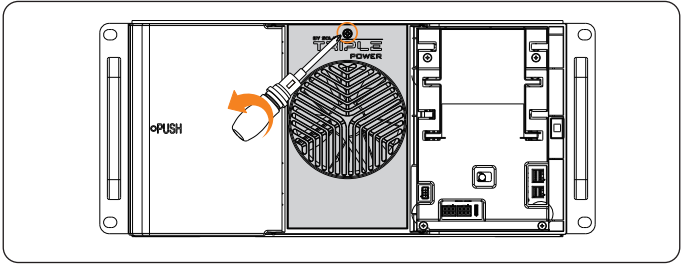

Figure 5-4 Removing the screw

Step 4: Unscrew the screws and remove the fan.

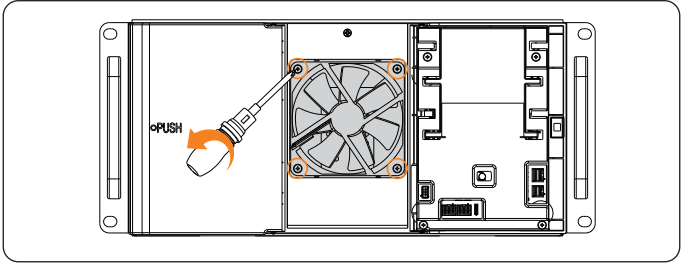

Figure 5-5 Removing the fan

Step 5: Install a new fan and connect the cables.

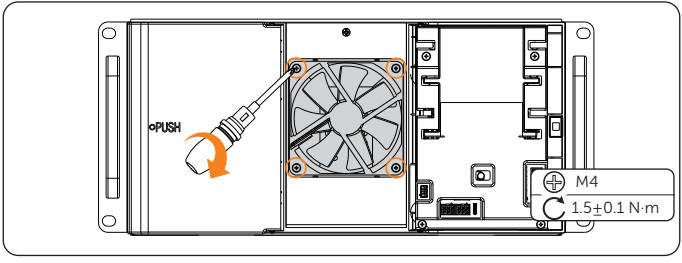

Figure 5-6 Installing a new fan

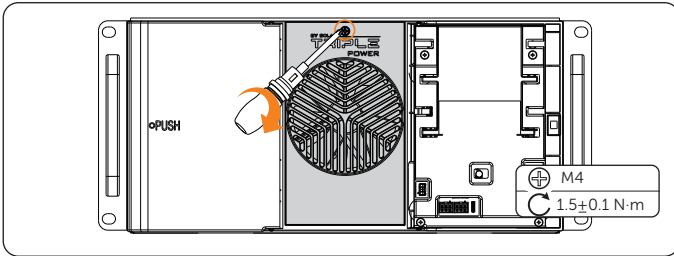

Figure 5-7 Installing the cover

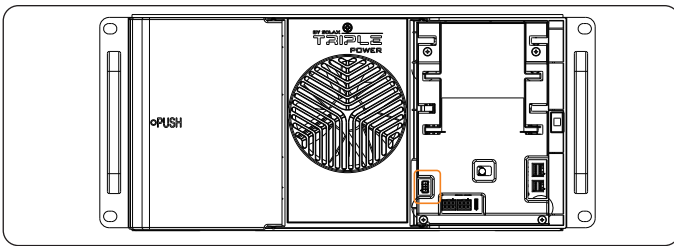

Figure 5-8 Connecting the cable

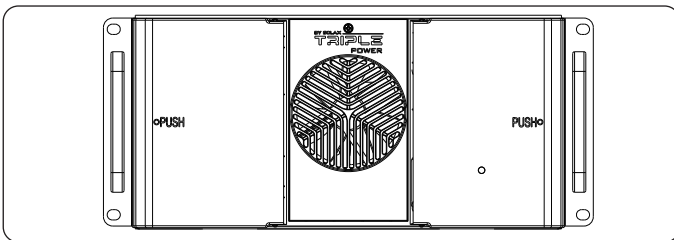

Figure 5-9 Closing the cover

Checking after replacement

For details of checking procedure after replacement, please refer to "28 Checking after Replacement".

6 Replacement of BMU

Prerequisites

- Fault locating:
 - a. View alarm information via cabinet screen, EMS1000 webpage, SolaXCloud App or troubleshooting manual.
 - b. Refer to the alarm handling suggestions in the alarm details.
 - c. Contact Solax and order replacement parts.
- Tools: Cross screwdriver, ladder.

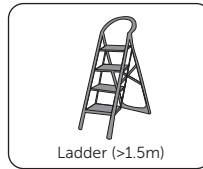
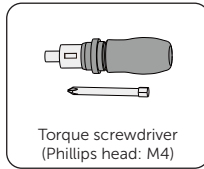

DANGER!

- Do not disassemble the battery violently. Otherwise, it may lead to battery pack short circuit, damage to the device (leakage, rupture), fire, or explosion.

WARNING!

- Before replacing the BMU, ensure that the system is powered off. Otherwise, electric shocks may occur.
- After the system powers off, there will still be the remaining electricity and heat which may cause electric shocks and body burns. Please wear personal protective equipment (PPE) and begin servicing the system five minutes after power off.
- Only qualified person can perform the maintenance for the device.

NOTICE!

- The replaced devices should be sent back to the local Solax warehouse.

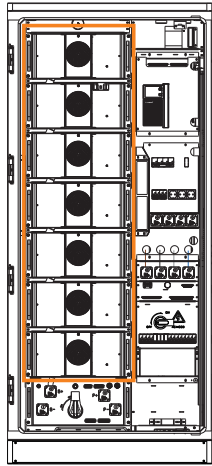

Figure 6-1 Position of the BMUs

Procedure

Step 1: Press to open the cover of the battery pack.

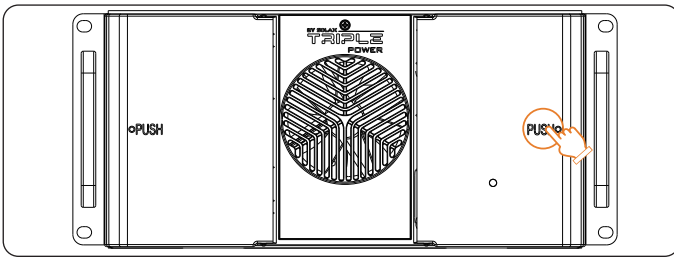

Figure 6-2 Opening the battery pack cover

Step 2: Remove the cable of the BMU.

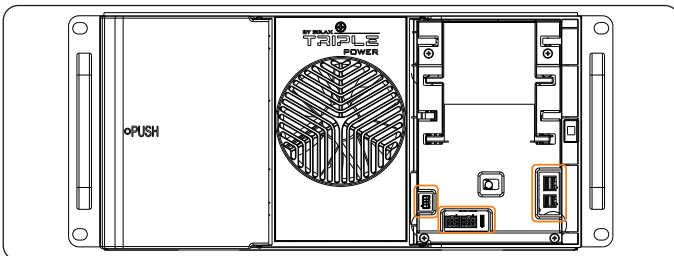

Figure 6-3 Removing the cable

Step 3: Remove the PCBA cover.

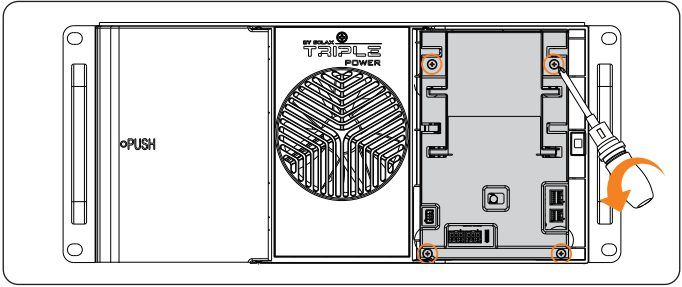

Figure 6-4 Removing the PCBA cover

Step 4: Removing the cables of the BMU.

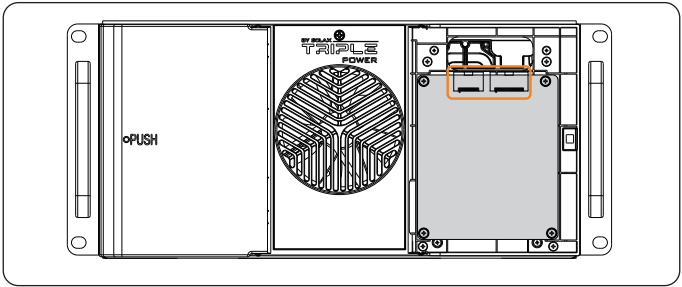

Figure 6-5 Removing the cables of the BMU

Step 5: Remove the BMU.

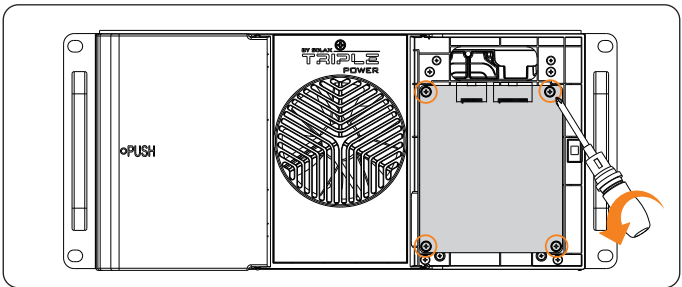

Figure 6-6 Removing the BMU

Step 6: Install a new BMU.

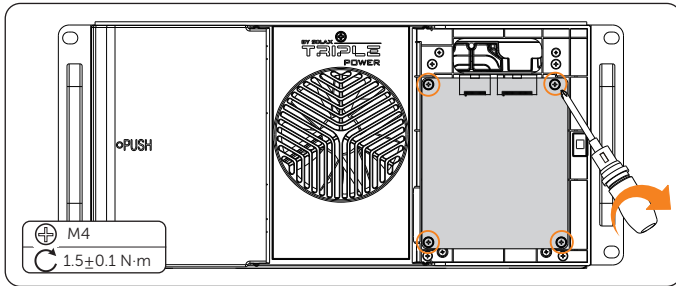

Figure 6-7 Installing a new BMU

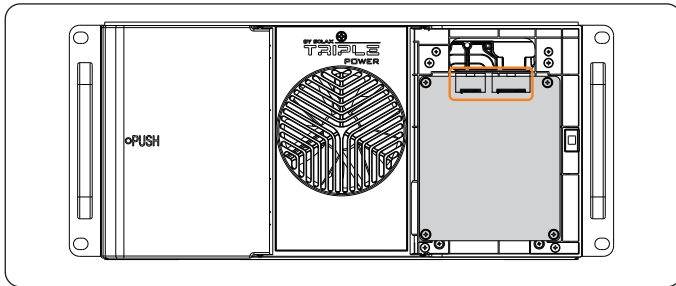

Figure 6-8 Connecting the cables of the BMU

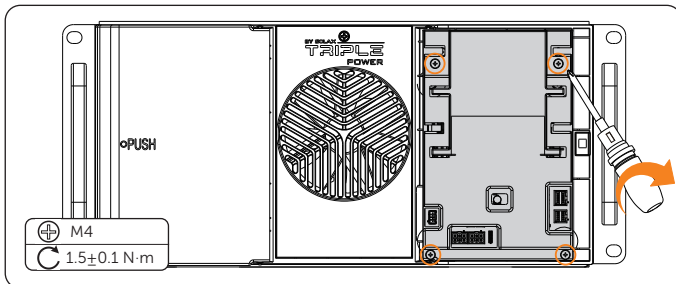

Figure 6-9 Installing the PCBA cover

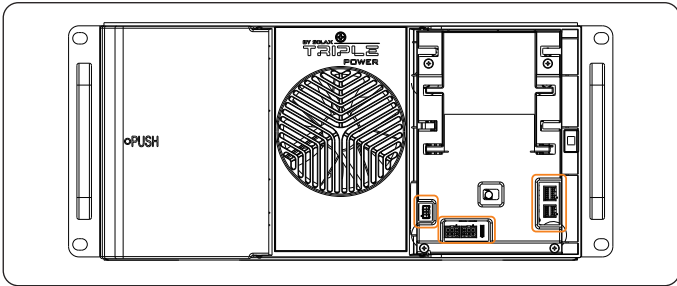

Figure 6-10 Connecting the cables

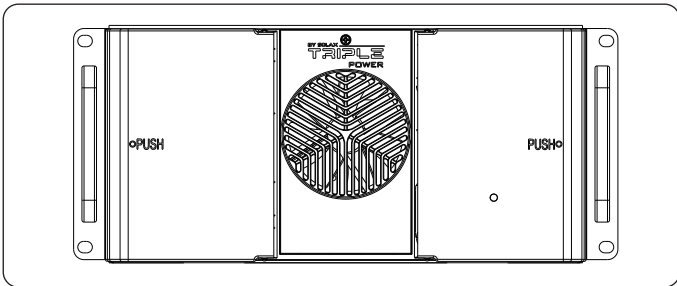

Figure 6-11 Closing the cover

Checking after replacement

- Step 1:** Power on the system. For details, refer to "2.4 Power On".
- Step 2:** Check whether the indicator on the battery pack front panel is flashing green light and check whether the battery pack communication is normal via EMS1000 webpage or SolaX Cloud App.

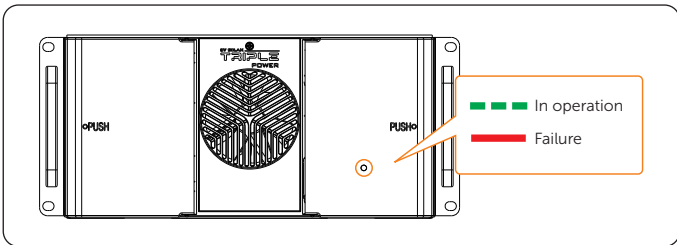
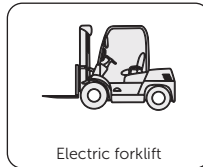
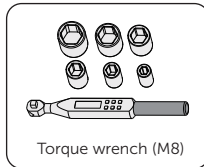
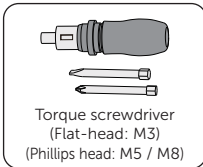

Figure 6-12 Battery pack indicator

7 Replacement of High-voltage Box

Prerequisites

- Fault locating:
 - a. View alarm information via cabinet screen, EMS1000 webpage, SolaXCloud App or troubleshooting manual.
 - b. Refer to the alarm handling suggestions in the alarm details.
 - c. Contact Solax and order replacement parts.
- Tools: Cross screwdriver, torque wrench, electric forklift, ladder.



WARNING!

- Before replacing the high-voltage box, ensure that the system is powered off. Otherwise, electric shocks may occur.
- After the system powers off, there will still be the remaining electricity and heat which may cause electric shocks and body burns. Please wear personal protective equipment (PPE) and begin servicing the system five minutes after power off.
- Only qualified person can perform the maintenance for the device.

NOTICE!

- The replaced devices should be sent back to the local Solax warehouse.

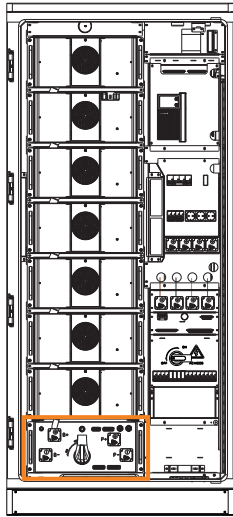

Figure 7-1 Position of the high-voltage box

Procedure

Step 1: Press to open the covers on both sides of the top and bottom battery packs.

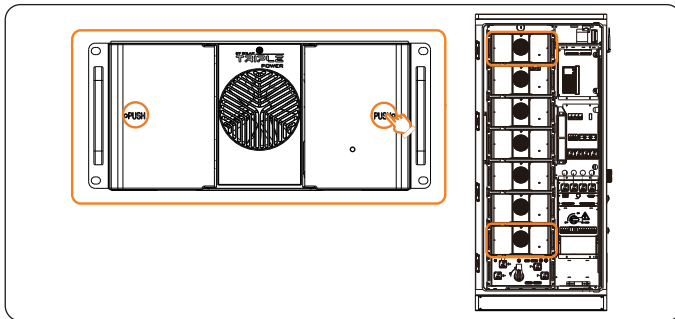

Figure 7-2 Opening the battery pack cover

Step 2: Remove the copper bar and cables.

1. Remove the cover of the negative pole of the top battery pack and remove the cable. Snap the cover of the negative pole.
2. Remove the covers of the positive copper bar of the bottom battery pack and the B-, B+, P- and P+ ports of the high-voltage box.
3. Unscrew the screws, remove the copper bar and cables.
4. Snap the covers of positive copper bar and B-, B+, P- and P+ ports. Unplug the cable from the circled area.

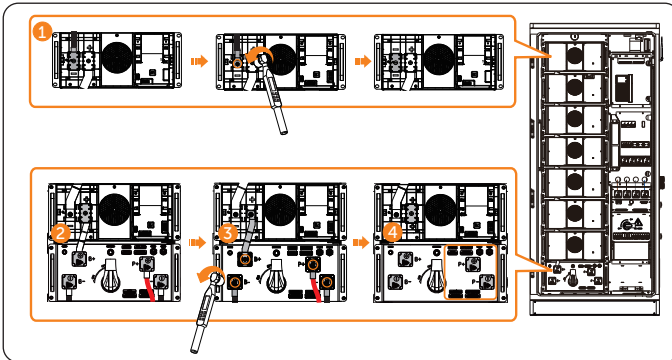

Figure 7-3 Removing the copper bars and cables

⚠ WARNING!

- After removing the copper bars, it is necessary to install the covers back, otherwise electric shock may occur.

Step 3: Unscrew the M5 screws on the baffle and remove the baffle. Unscrew the M8 screws on the high-voltage box.

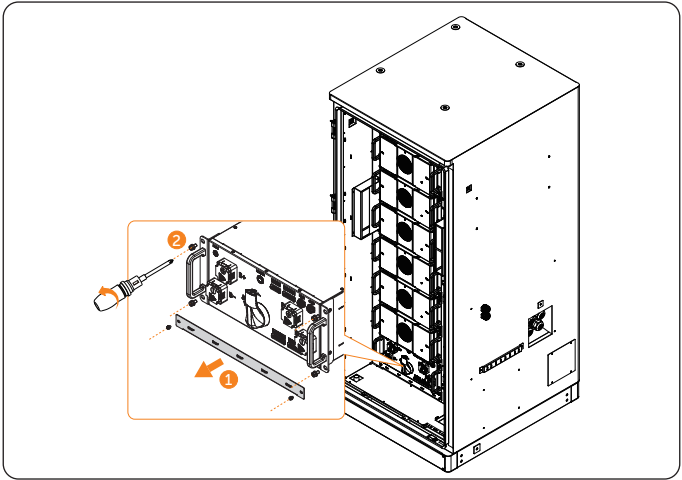

Figure 7-4 Removing the baffle

Step 4: Draw the high-voltage box onto a forklift and transport it with the forklift.

Step 5: Transport the new high-voltage box to the designated location with a forklift and manually push the high-voltage box into the cabinet. Secure the high-voltage box with M8 screws. Install the baffle and secure with M5 screws.

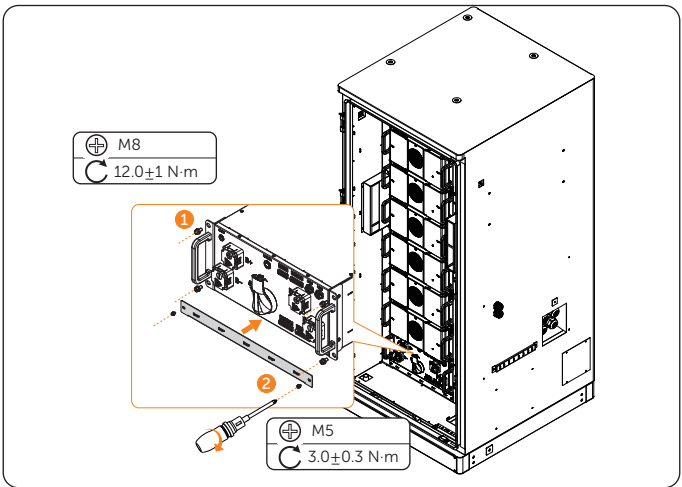

Figure 7-5 Installing the high-voltage box

Step 6: Install the copper bar and cables.

1. Remove the cover of the negative pole of the top battery pack. Install the negative cable and snap the cover.
2. Remove the covers of the positive copper bar of the bottom battery pack and B+, B-, P- and P+ ports of the high-voltage box
3. Fasten the M8 screws to secure the copper and cables.
4. Snap the covers. Plug the connectors and terminal blocks of the circled area according to silkscreen and cable markings, tighten the M3 fixing screws of the terminal blocks (torque: 0.5 ± 0.1 N·m) with a flat-head screwdriver.
5. Close the covers of the battery packs.

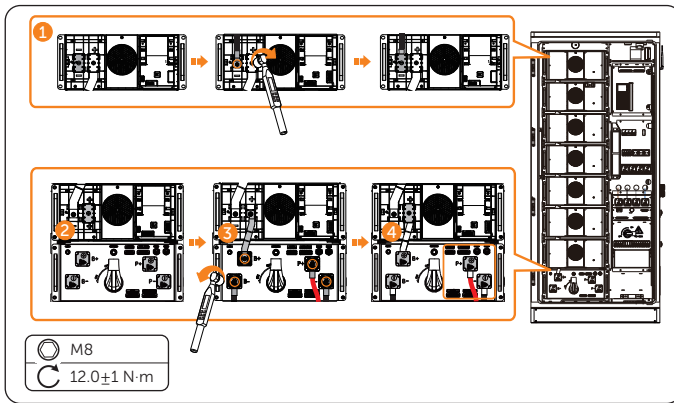

Figure 7-6 Installing the high-voltage box

Step 7: Long press the button of the high-voltage box for 10 seconds for address assignment.

Figure 7-7 Address assignment

Checking after replacement

For details of checking procedure after replacement, please refer to “28 Checking after Replacement”.

8 Replacement of SBMU

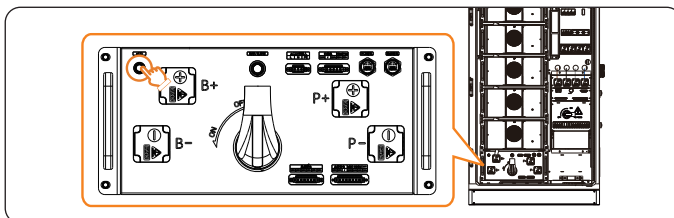
Prerequisites

- Fault locating:
 - a. View alarm information via cabinet screen, EMS1000 webpage, SolaXCloud App or troubleshooting manual.
 - b. Refer to the alarm handling suggestions in the alarm details.
 - c. Contact Solax and order replacement parts.
- Tools: Cross screwdriver, torque wrench, electric forklift, ladder.

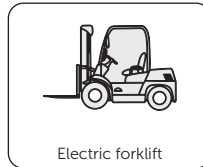
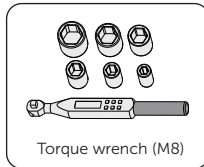
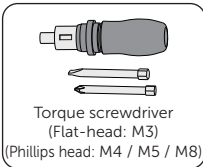

WARNING!

- Before replacing the SBMU, ensure that the system is powered off. Otherwise, electric shocks may occur.
- After the system powers off, there will still be the remaining electricity and heat which may cause electric shocks and body burns. Please wear personal protective equipment (PPE) and begin servicing the system five minutes after power off.
- Only qualified person can perform the maintenance for the device.

NOTICE!

- The replaced devices should be sent back to the local Solax warehouse.

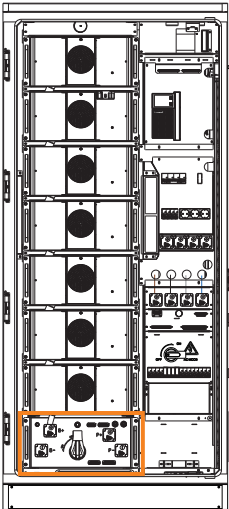

Figure 8-1 Position of the SBMU

Procedure

Step 1: Press to open the covers on both sides of the top and bottom battery packs.

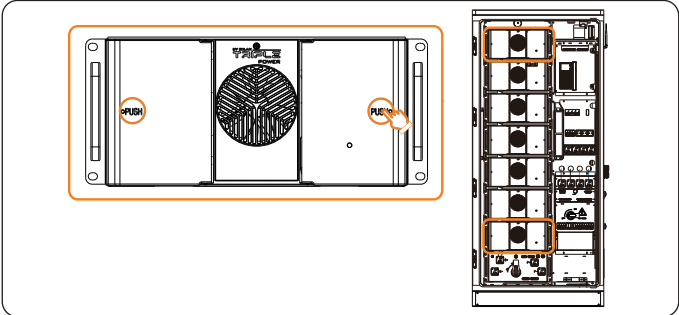

Figure 8-2 Opening the battery pack cover

Step 2: Remove the copper bar and cables.

1. Remove the cover of the negative pole of the top battery pack and remove the cable. Snap the cover of the negative pole.
2. Remove the covers of the positive copper bar of the bottom battery pack and the B-, B+, P- and P+ ports of the high-voltage box.
3. Unscrew the screws, remove the copper bar and cables.
4. Snap the covers of positive copper bar and B-, B+, P- and P+ ports. Unplug the cable from the circled area.

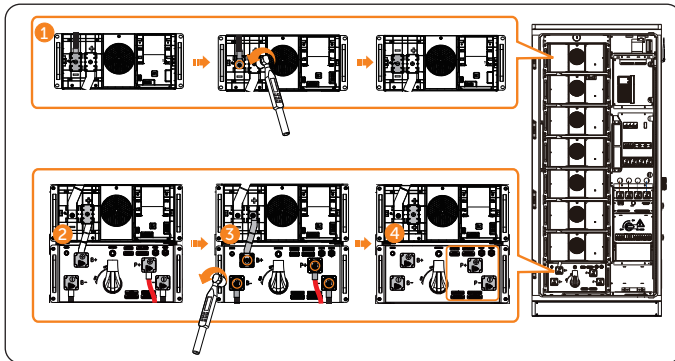

Figure 8-3 Removing the copper bars and cables

WARNING!

- After removing the copper bars, it is necessary to install the covers back, otherwise electric shock may occur.

Step 3: Unscrew the M5 screws on the baffle and remove the baffle. Unscrew the M8 screws on the high-voltage box.

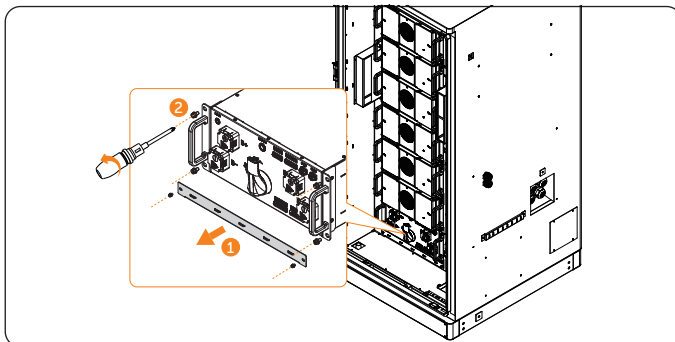

Figure 8-4 Removing the baffle

Step 4: Draw the high-voltage box onto a forklift and transport it with the forklift.

Step 5: Unscrew the M4 screws and remove the top cover of the high-voltage box.

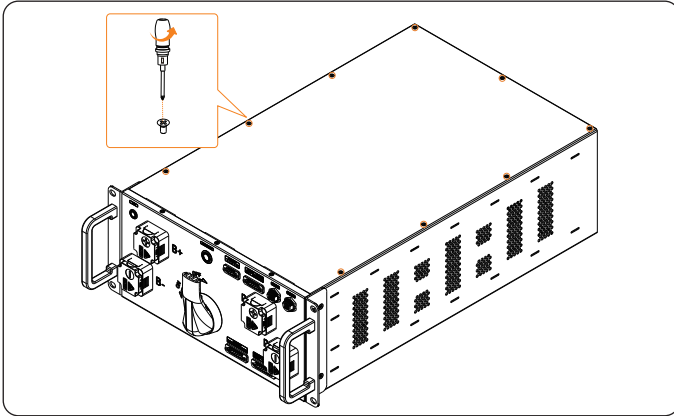

Figure 8-5 Removing the top cover

Step 6: Remove the cables of the SBMU. Unscrew the M4 screws and remove the SBMU.

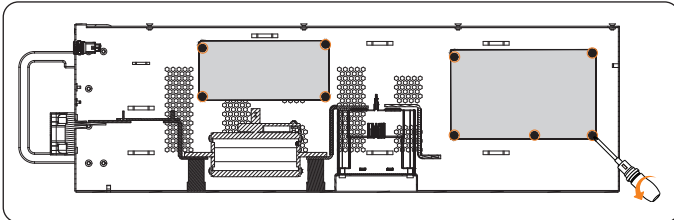

Figure 8-6 Removing the SBMU (right view)

Step 7: Connect the cables of the SBMU. Install new SBMU and secure with screws.

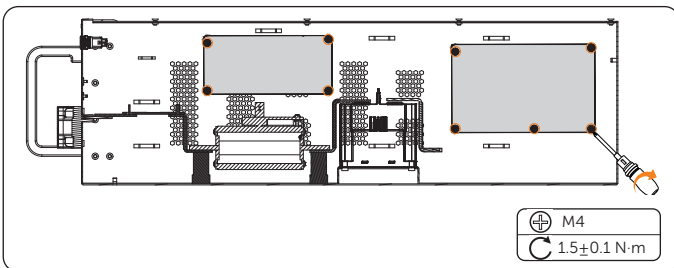

Figure 8-7 Installing the contactors (right view)

Step 8: Install the top cover of the high-voltage box and secure with screws.

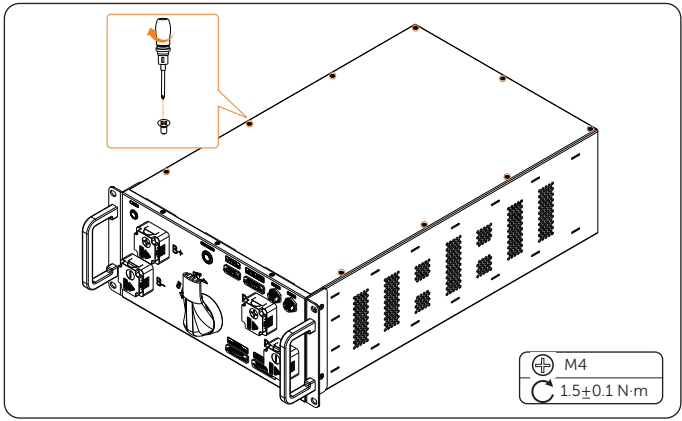

Figure 8-8 Installing the top cover

Step 9: Transport the new high-voltage box to the designated location with a forklift and manually push the high-voltage box into the cabinet. Secure the high-voltage box with M8 screws. Install the baffle and secure with M5 screws.

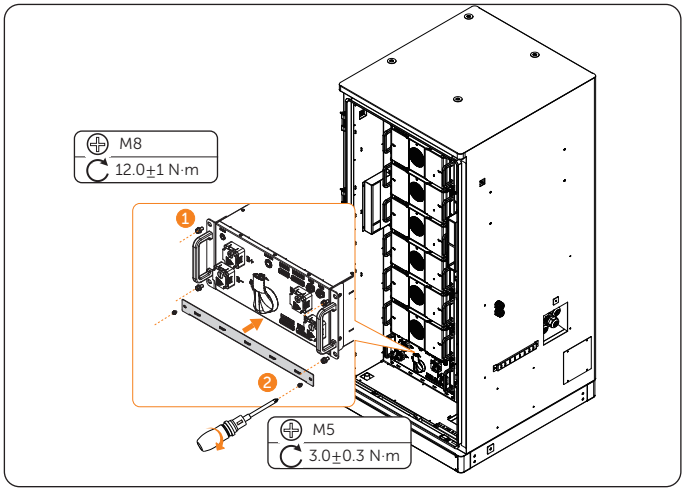

Figure 8-9 Installing the high-voltage box

Step 10: Install the copper bar and cables.

1. Remove the cover of the negative pole of the top battery pack. Install the negative cable and snap the cover.
2. Remove the covers of the positive copper bar of the bottom battery pack and B-, B+, P- and P+ ports of the high-voltage box
3. Fasten the M8 screws to secure the copper and cables.
4. Snap the covers. Plug the connectors and terminal blocks of the circled area according to silkscreen and cable markings, tighten the M3 fixing screws of the terminal blocks (torque: 0.5 ± 0.1 N·m) with a flat-head screwdriver.
5. Close the covers of the battery packs.

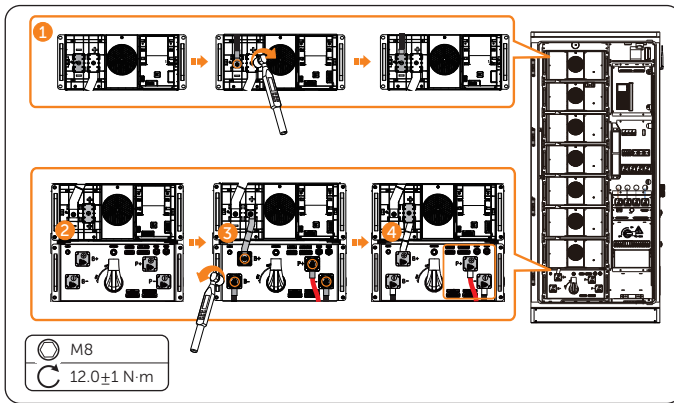

Figure 8-10 Installing the high-voltage box

Checking after replacement

Step 1: Power on the system. For details, refer to "2.4 Power On".

Step 2: Check whether the main voltage can be acquired, whether the relay can be closed and whether the communication is normal via EMS1000 webpage or SolaX Cloud App.

9 Replacement of High-voltage Box Fuse

Prerequisites

- Fault locating:
 - a. View alarm information via cabinet screen, EMS1000 webpage, SolaXCloud App or troubleshooting manual.
 - b. Refer to the alarm handling suggestions in the alarm details.
 - c. Contact Solax and order replacement parts.
- Tools: Cross screwdriver, torque wrench, electric forklift, multimeter, ladder.

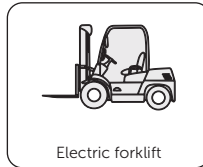
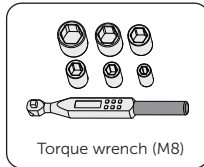
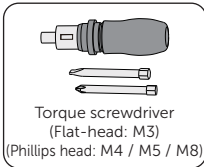

WARNING!

- Before replacing the high-voltage box fuse, ensure that the system is powered off. Otherwise, electric shocks may occur.
- After the system powers off, there will still be the remaining electricity and heat which may cause electric shocks and body burns. Please wear personal protective equipment (PPE) and begin servicing the system five minutes after power off.
- Only qualified person can perform the maintenance for the device.

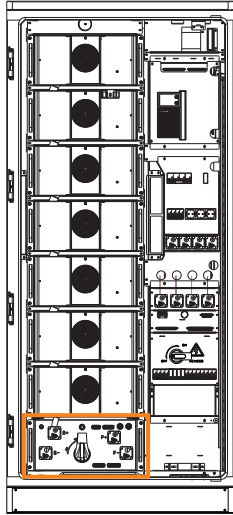

Figure 9-1 Position of the high-voltage box fuses

Procedure

Step 1: Press to open the covers on both sides of the top and bottom battery packs.

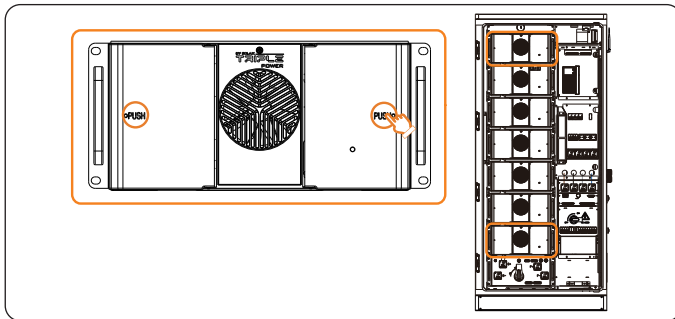

Figure 9-2 Opening the battery pack cover

Step 2: Remove the copper bar and cables.

1. Remove the cover of the negative pole of the top battery pack and remove the cable. Snap the cover of the negative pole.
2. Remove the covers of the positive copper bar of the bottom battery pack and the B-, B+, P- and P+ ports of the high-voltage box.
3. Unscrew the screws, remove the copper bar and cables.
4. Snap the covers of positive copper bar and B-, B+, P- and P+ ports. Unplug the cable from the circled area.

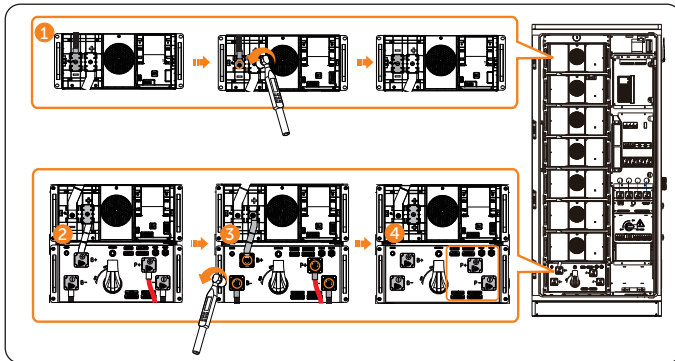

Figure 9-3 Removing the copper bars and cables

WARNING!

- After removing the copper bars, it is necessary to install the covers back, otherwise electric shock may occur.

Step 3: Unscrew the M5 screws on the baffle and remove the baffle. Unscrew the M8 screws on the high-voltage box.

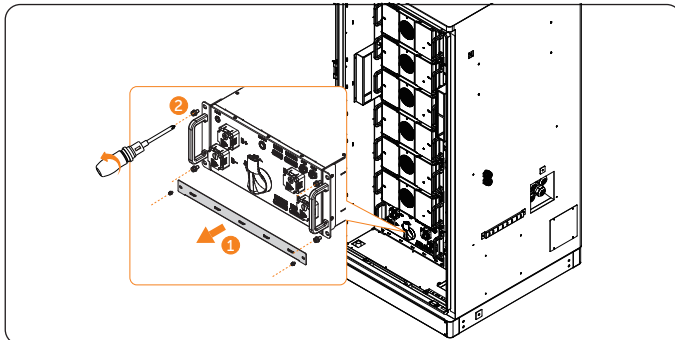

Figure 9-4 Removing the baffle

Step 4: Draw the high-voltage box onto a forklift and transport it with the forklift.

Step 5: Unscrew the M4 screws and remove the top cover of the high-voltage box.

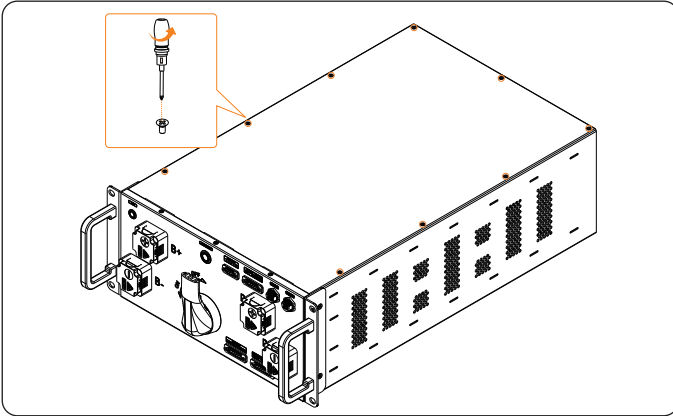

Figure 9-5 Removing the top cover

Step 6: Use a multimeter to measure the fuse ON-OFF status (ON for normal, OFF for abnormal).

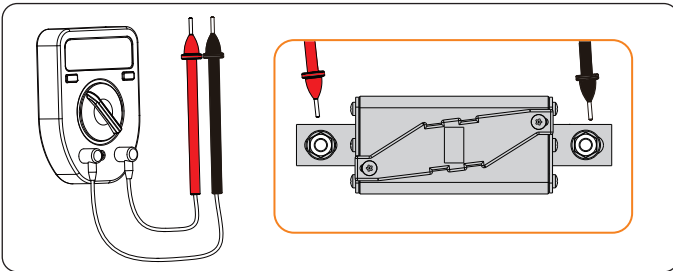

Figure 9-6 Measuring the fuse ON-OFF status

Step 7: Remove the cables of the fuse. Loosen the M8 nuts from the fuses and remove the fuses.

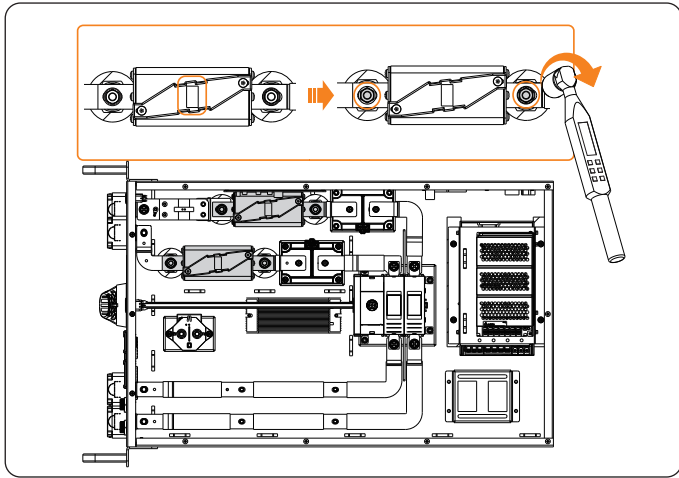

Figure 9-7 Removing the fuses (top view)

Step 8: Install new fuses and secure with nuts. Connect the cables of the fuse.

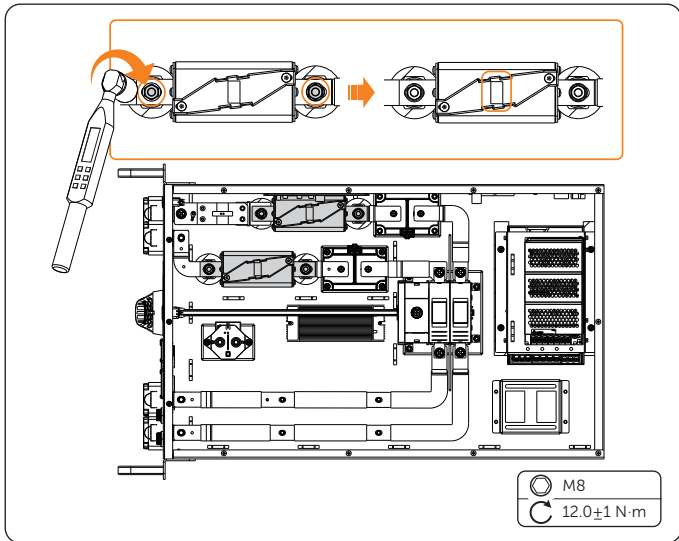

Figure 9-8 Installing the fuses (top view)

Step 9: Use a multimeter to measure the replaced fuse ON-OFF status (ON for normal, OFF for abnormal).

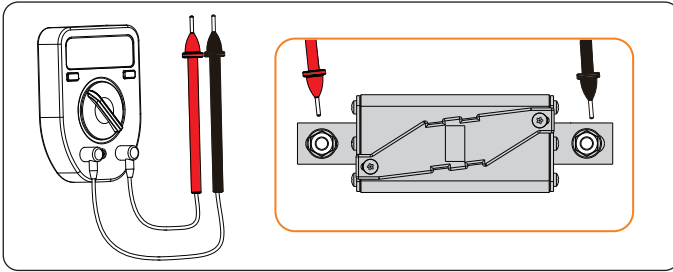

Figure 9-9 Measuring the fuse ON-OFF status

Step 10: Install the top cover of the high-voltage and secure with screws.

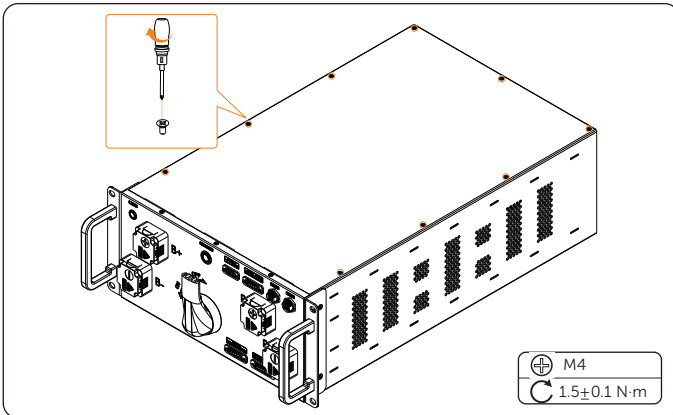

Figure 9-10 Installing the top cover

Step 11: Transport the new high-voltage box to the designated location with a forklift and manually push the high-voltage box into the cabinet. Secure the high-voltage box with M8 screws. Install the baffle and secure with M5 screws.

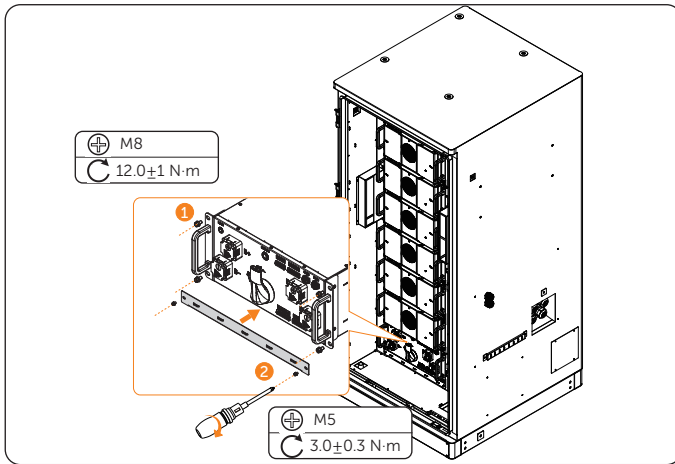

Figure 9-11 Installing the high-voltage box

Step 12: Install the copper bar and cables.

1. Remove the cover of the negative pole of the top battery pack. Install the negative cable and snap the cover.
2. Remove the covers of the positive copper bar of the bottom battery pack and B-, B+, P- and P+ ports of the high-voltage box
3. Fasten the M8 screws to secure the copper and cables.
4. Snap the covers. Plug the connectors and terminal blocks of the circled area according to silkscreen and cable markings, tighten the M3 fixing screws of the terminal blocks (torque: $0.5 \pm 0.1 \text{ N}\cdot\text{m}$) with a flat-head screwdriver.
5. Close the covers of the battery packs.

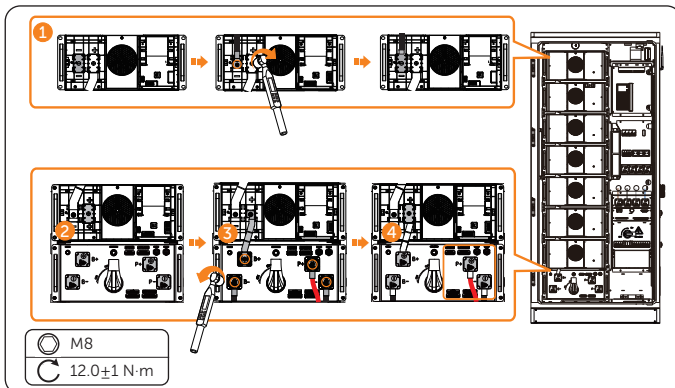
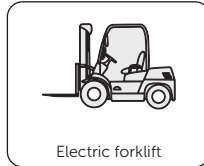
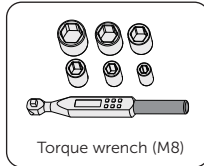
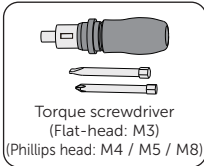

Figure 9-12 Installing the high-voltage box

10 Replacement of High-voltage Box Contactor

Prerequisites

- Fault locating:
 - a. View alarm information via cabinet screen, EMS1000 webpage, SolaXCloud App or troubleshooting manual.
 - b. Refer to the alarm handling suggestions in the alarm details.
 - c. Contact Solax and order replacement parts.
- Tools: Cross screwdriver, torque wrench, electric forklift, multimeter, ladder.



WARNING!

- Before replacing the high-voltage box contactor, ensure that the system is powered off. Otherwise, electric shocks may occur.
- After the system powers off, there will still be the remaining electricity and heat which may cause electric shocks and body burns. Please wear personal protective equipment (PPE) and begin servicing the system five minutes after power off.
- Only qualified person can perform the maintenance for the device.

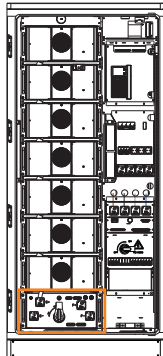

Figure 10-1 Position of the high-voltage box contactors

Procedure

Step 1: Press to open the covers on both sides of the top and bottom battery packs.

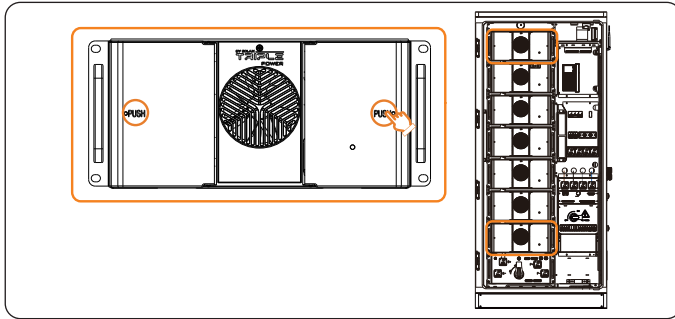

Figure 10-2 Opening the battery pack cover

Step 2: Remove the copper bar and cables.

1. Remove the cover of the negative pole of the top battery pack and remove the cable. Snap the cover of the negative pole.
2. Remove the covers of the positive copper bar of the bottom battery pack and the B-, B+, P- and P+ ports of the high-voltage box.
3. Unscrew the screws, remove the copper bar and cables.
4. Snap the covers of positive copper bar and B-, B+, P- and P+ ports. Unplug the cable from the circled area.

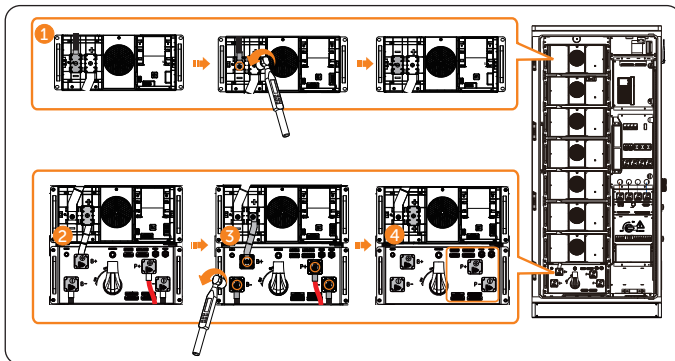

Figure 10-3 Removing the copper bars and cables

WARNING!

- After removing the copper bars, it is necessary to install the covers back, otherwise electric shock may occur.

Step 3: Unscrew the M5 screws on the baffle and remove the baffle. Unscrew the M8 screws on the high-voltage box.

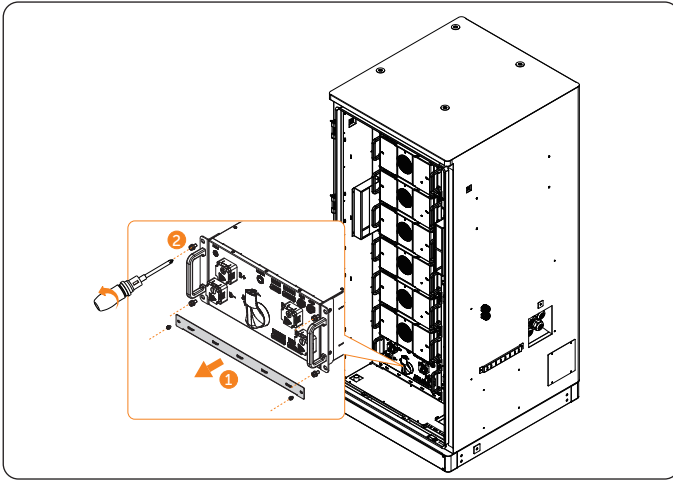

Figure 10-4 Removing the baffle

Step 4: Draw the high-voltage box onto a forklift and transport it with the forklift.

Step 5: Unscrew the M4 screws and remove the top cover of the high-voltage box.

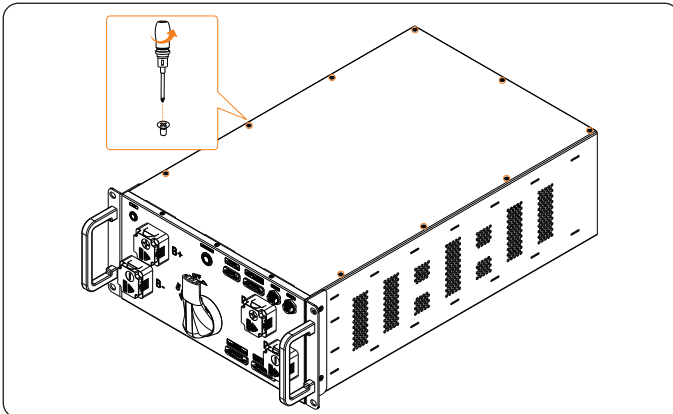

Figure 10-5 Removing the top cover

Step 6: Use a multimeter to measure the contactor ON-OFF status (ON for abnormal, OFF for normal).

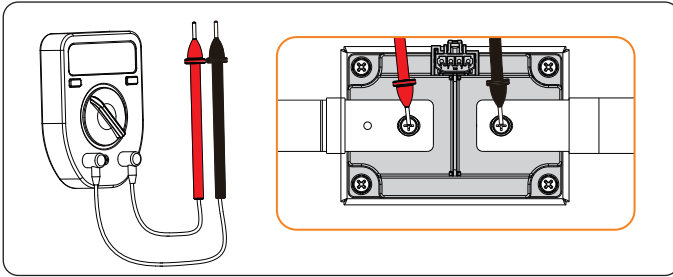

Figure 10-6 Measuring the contactor ON-OFF status

Step 7: Remove the cables of the fuse. Loosen the M8 nuts from the fuses and remove the fuses.

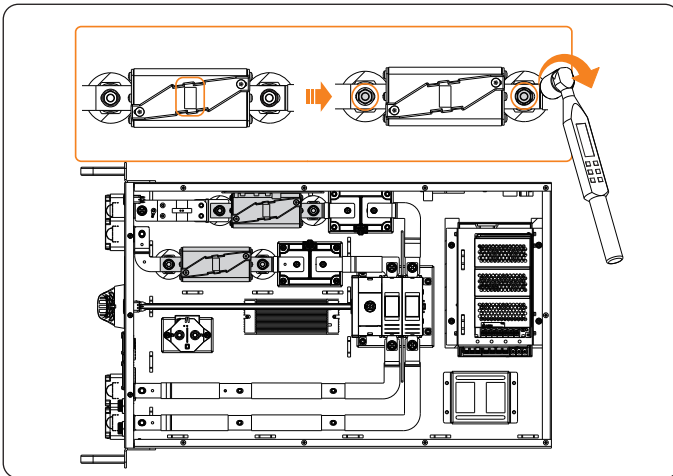

Figure 10-7 Removing the fuses (top view)

Step 8: Remove cables from the contactors. Unscrew the M5 screws and M8 nut of the copper bars on the contactors, remove the copper bar. Unscrew the M6 screws and remove the contactors.

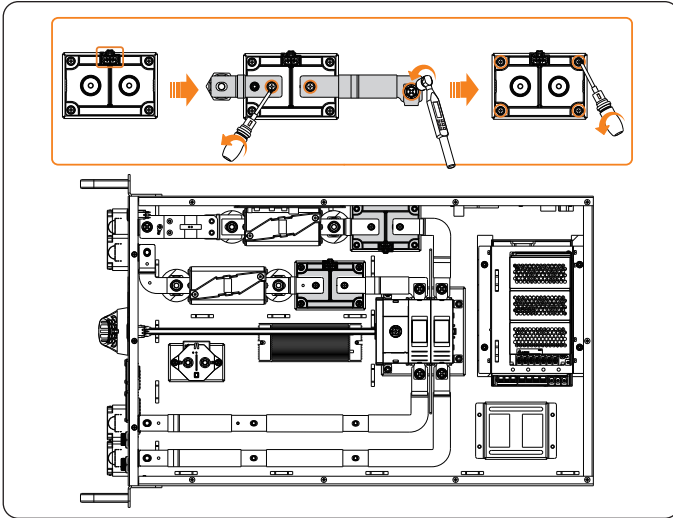

Figure 10-8 Removing the contactors (top view)

Step 9: Install new contactors, and secure with screws. Install the copper bar and connect the cable.

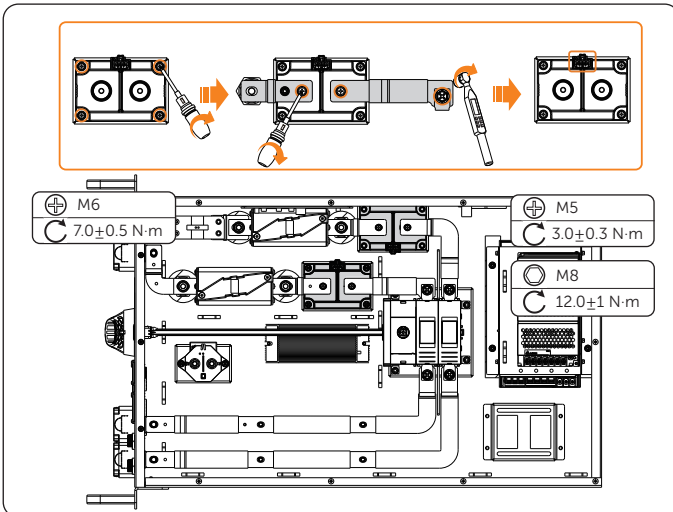

Figure 10-9 Installing the contactors (top view)

Step 10: Install fuses and secure with nuts. Connect the cables of the fuse.

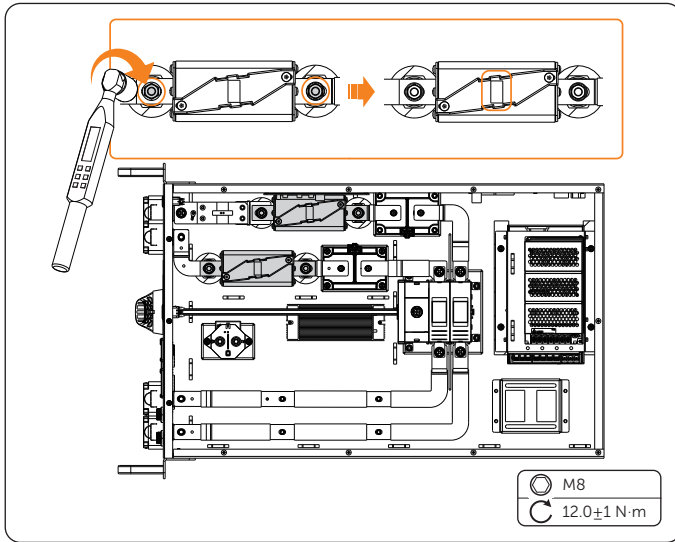

Figure 10-10 Installing the fuses (top view)

Step 11: Use a multimeter to measure the replaced contactor ON-OFF status (ON for abnormal, OFF for normal).

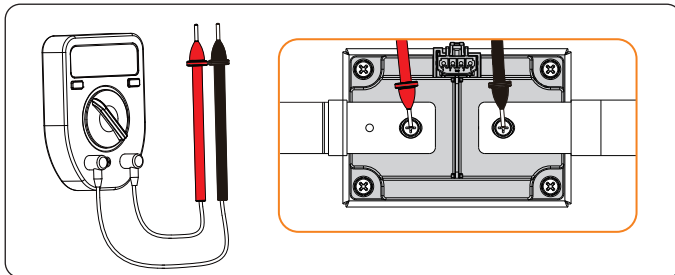

Figure 10-11 Measuring the contactor ON-OFF status

Step 12: Install the top cover of the high-voltage and secure with screws.

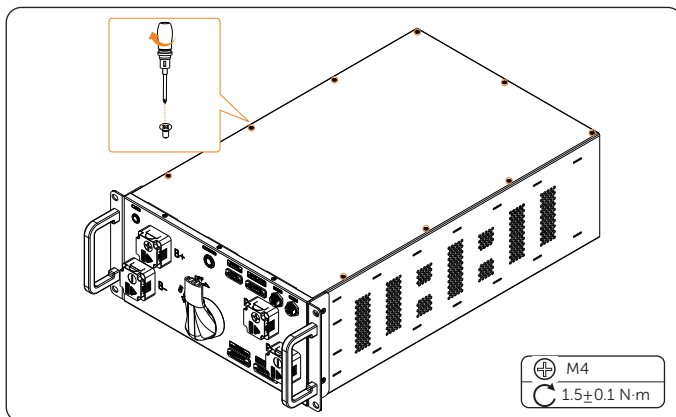

Figure 10-12 Installing the top cover

Step 13: Transport the new high-voltage box to the designated location with a forklift and manually push the high-voltage box into the cabinet. Secure the high-voltage box with M8 screws. Install the baffle and secure with M5 screws.

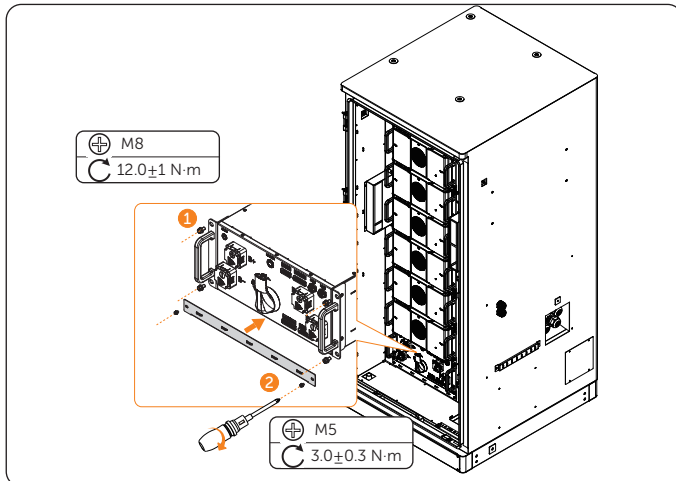

Figure 10-13 Installing the high-voltage box

Step 14: Install the copper bar and cables.

1. Remove the cover of the negative pole of the top battery pack. Install the negative cable and snap the cover.
2. Remove the covers of the positive copper bar of the bottom battery pack and B-, B+, P- and P+ ports of the high-voltage box
3. Fasten the M8 screws to secure the copper and cables.
4. Snap the covers. Plug the connectors and terminal blocks of the circled area according to silkscreen and cable markings, tighten the M3 fixing screws of the terminal blocks (torque: 0.5 ± 0.1 N·m) with a flat-head screwdriver.
5. Close the covers of the battery packs.

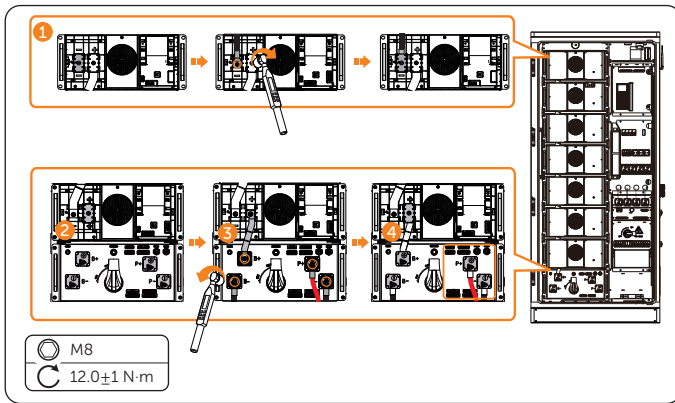
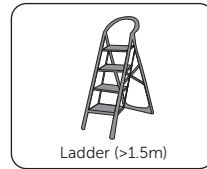
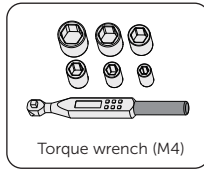
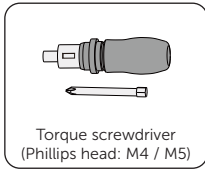

Figure 10-14 Installing the high-voltage box

11 Replacement of EMS

Prerequisites

- Fault locating:
 - a. View alarm information via cabinet screen, EMS1000 webpage, SolaXCloud App or troubleshooting manual.
 - b. Refer to the alarm handling suggestions in the alarm details.
 - c. Contact Solax and order replacement parts.
- Tools: Cross screwdriver, torque wrench, ladder.



WARNING!

- Before replacing the EMS, ensure that the system is powered off. Otherwise, electric shocks may occur.
- After the system powers off, there will still be the remaining electricity and heat which may cause electric shocks and body burns. Please wear personal protective equipment (PPE) and begin servicing the system five minutes after power off.
- Only qualified person can perform the maintenance for the device.

NOTICE!

- The replaced devices should be sent back to the local Solax warehouse.

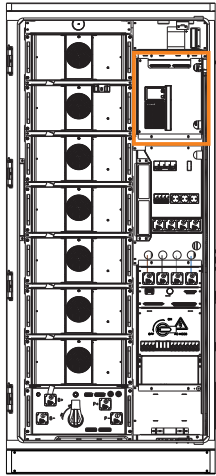

Figure 11-1 Position of the EMS

Procedure

Step 1: Unscrew the M5 screws on the front panel and remove the front panel.

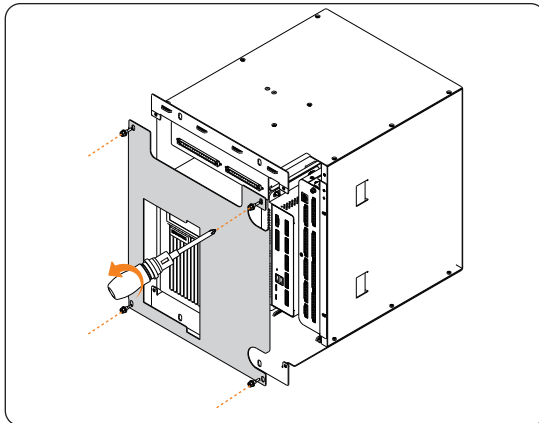

Figure 11-2 Removing the front panel

Step 2: Remove cables from the EMS.

Step 3: Unscrew the M4 screws on the sheet metal.

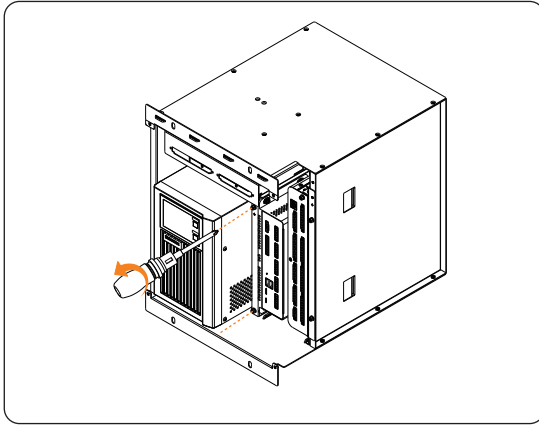

Figure 11-3 Unscrewing screws on the sheet metal

Step 4: Pull out the EMS with the sheet metal, loosen the M4 nuts and remove the EMS from the sheet metal.

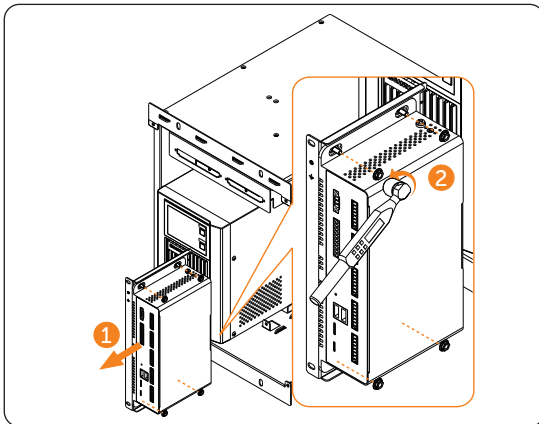

Figure 11-4 Removing the EMS

Step 5: Install a new EMS and connect the EMS cables according to silkscreen and cable markings.

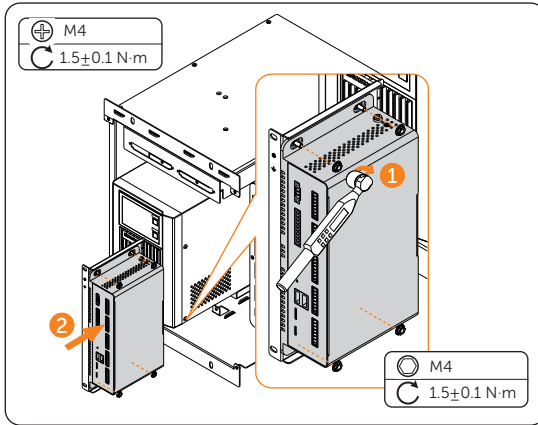

Figure 11-5 Installing the EMS

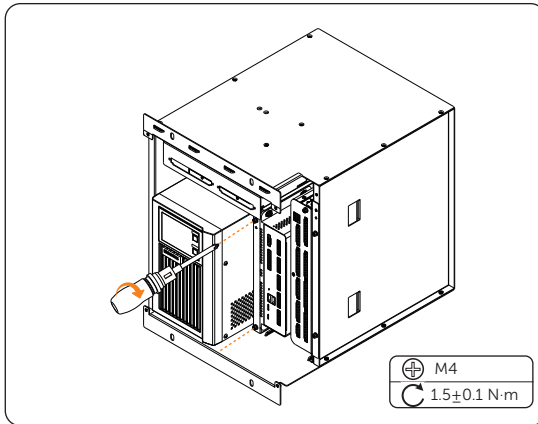

Figure 11-6 Installing the sheet metal

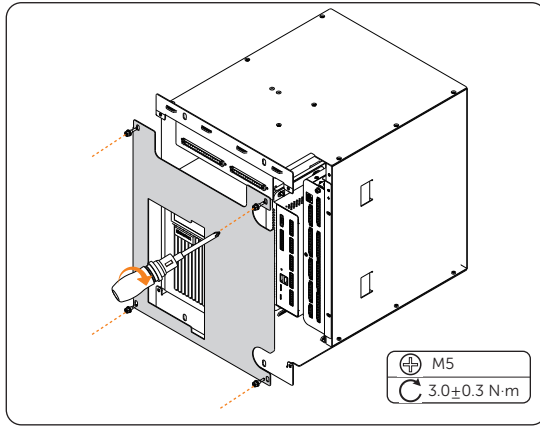

Figure 11-7 Installing the front panel

Checking after replacement

For details of checking procedure after replacement, please refer to “28 Checking after Replacement”.

12 Replacement of I/O Module

Prerequisites

- Fault locating:
 - a. View alarm information via cabinet screen, EMS1000 webpage, SolaXCloud App or troubleshooting manual.
 - b. Refer to the alarm handling suggestions in the alarm details.
 - c. Contact Solax and order replacement parts.
- Tools: Cross screwdriver, torque wrench, ladder.

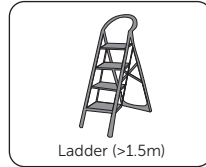
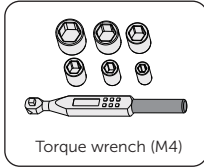
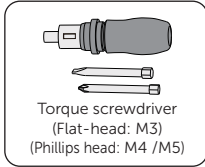

WARNING!

- Before replacing the I/O module, ensure that the system is powered off. Otherwise, electric shocks may occur.
- After the system powers off, there will still be the remaining electricity and heat which may cause electric shocks and body burns. Please wear personal protective equipment (PPE) and begin servicing the system five minutes after power off.
- Only qualified person can perform the maintenance for the device.

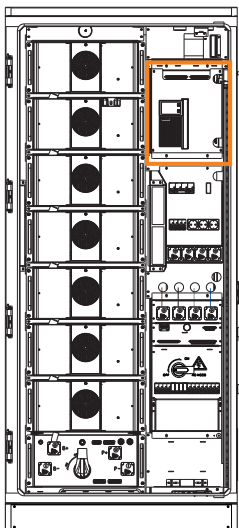

Figure 12-1 Position of the I/O module

Procedure

Step 1: Unscrew the M5 screws on the front panel and remove the front panel.

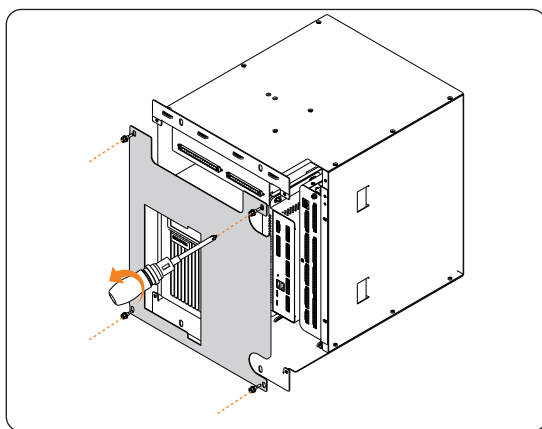

Figure 12-2 Removing the front panel

Step 2: Loosen the M3 fixing screws of the terminal blocks and remove the terminal blocks of I/O module.

Step 3: Unscrew the M4 screws on the sheet metal.

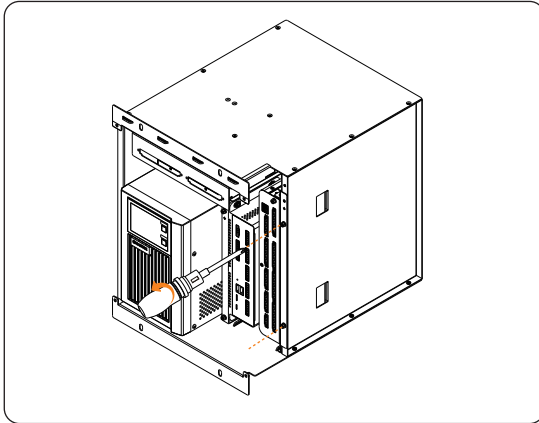

Figure 12-3 Unscrewing screws on the sheet metal

Step 4: Pull out the I/O module with the sheet metal, loosen the M4 nuts and remove the I/O module from the sheet metal.

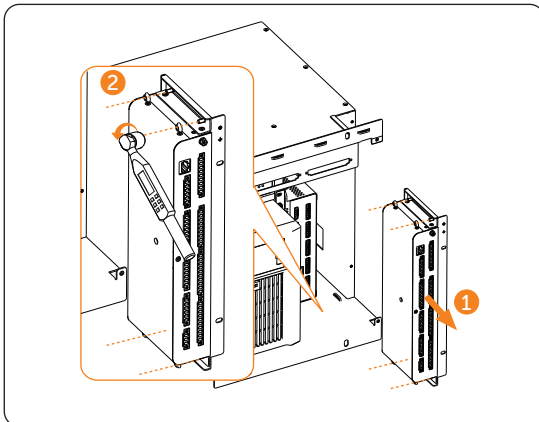

Figure 12-4 Removing the I/O module

Step 5: Install a new I/O module, connect the I/O module cables according to silkscreen and cable markings, tighten the M3 fixing screws of the terminal blocks (torque: 0.5 ± 0.1 N·m) with a flat-head screwdriver.

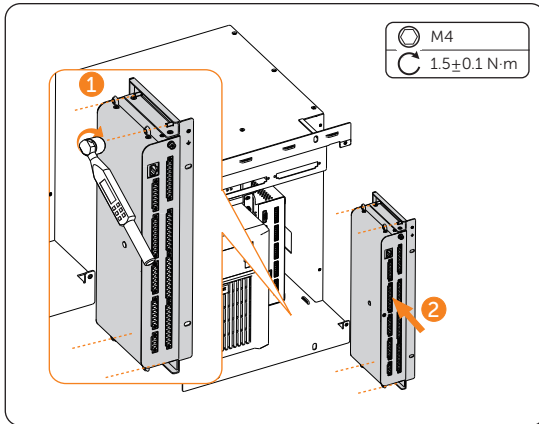

Figure 12-5 Installing the I/O module

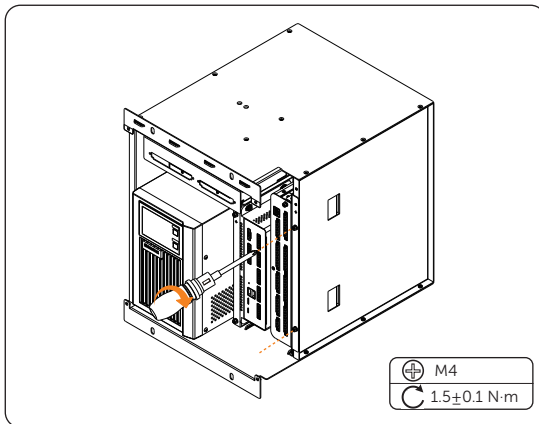

Figure 12-6 Installing the sheet metal

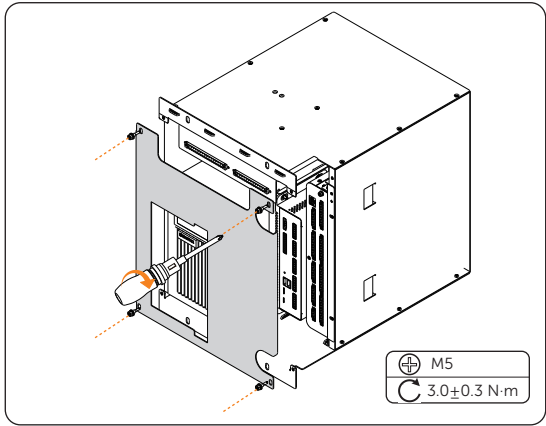

Figure 12-7 Installing the front panel

Checking after replacement

For details of checking procedure after replacement, please refer to “28 Checking after Replacement”.

13 Replacement of UPS

Prerequisites

- Fault locating:
 - a. View alarm information via cabinet screen, EMS1000 webpage, SolaXCloud App or troubleshooting manual.
 - b. Refer to the alarm handling suggestions in the alarm details.
 - c. Contact Solax and order replacement parts.
- Tools: Cross screwdriver, ladder.

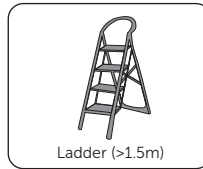
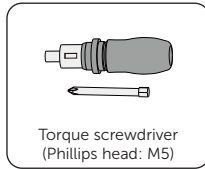

- At least two persons are required to replace the component.

WARNING!

- Before replacing the UPS, ensure that the system is powered off. Otherwise, electric shocks may occur.
- After the system powers off, there will still be the remaining electricity and heat which may cause electric shocks and body burns. Please wear personal protective equipment (PPE) and begin servicing the system five minutes after power off.

NOTICE!

- The replaced devices should be sent back to the local Solax warehouse.

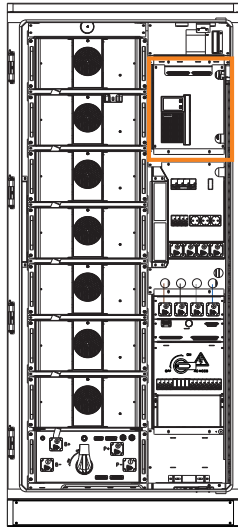

Figure 13-1 Position of the UPS

Procedure

Step 1: Unscrew the M5 screws on the front panel and remove the front panel.

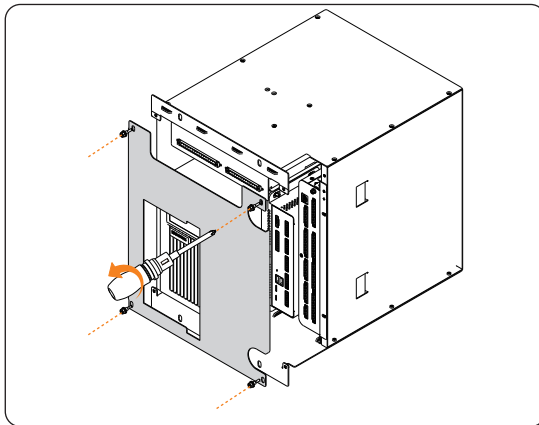

Figure 13-2 Removing the front panel

Step 2: Pull out the UPS.

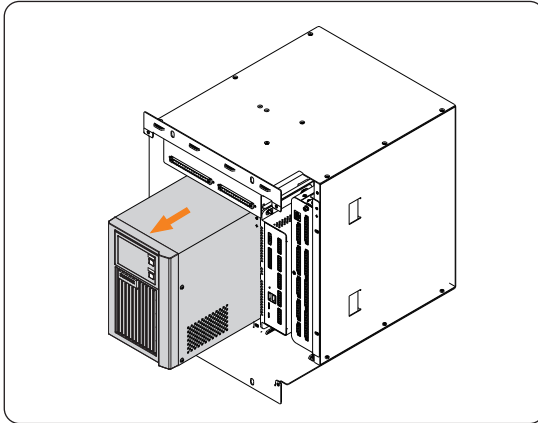

Figure 13-3 Removing the UPS

Step 3: Remove the cables on the back of the UPS

Step 4: Connect the new UPS cables and install the UPS.

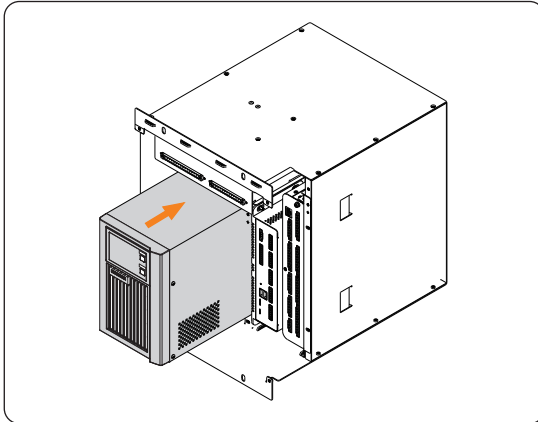

Figure 13-4 Installing the UPS

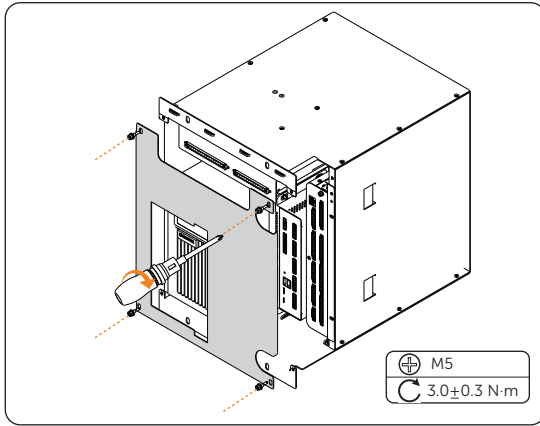

Figure 13-5 Installing the front panel

Checking after replacement

- Step 1:** Check whether the UPS can be powered on.
- Step 2:** Check whether the function switching on the UPS screen is normal.

14 Replacement of HUB

Prerequisites

- Fault locating:
 - a. Remove the front panel.
 - b. The indicator of HUB is off.
- Tools: Cross screwdriver, ladder.

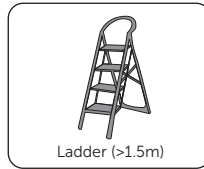
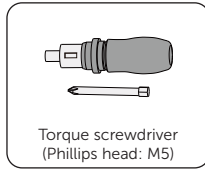

WARNING!

- Before replacing the HUB, ensure that the system is powered off. Otherwise, electric shocks may occur.
- After the system powers off, there will still be the remaining electricity and heat which may cause electric shocks and body burns. Please wear personal protective equipment (PPE) and begin servicing the system five minutes after power off.
- Only qualified person can perform the maintenance for the device.

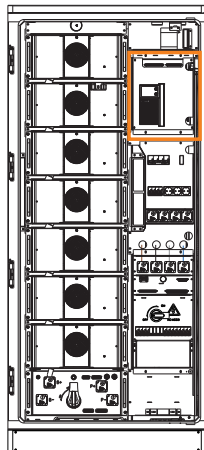

Figure 14-1 Position of the HUB

Procedure

Step 1: Unscrew the M5 screws on the front panel and remove the front panel.

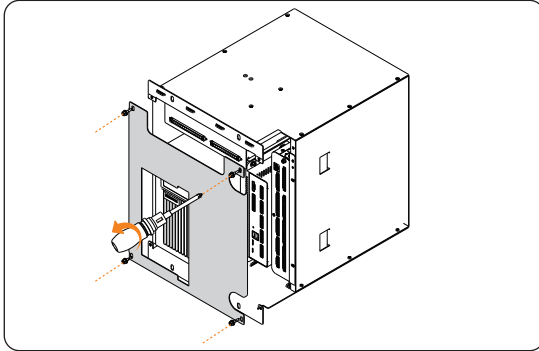

Figure 14-2 Removing the front panel

Step 2: Remove cables from the HUB.

Step 3: Slide the HUB up until it is above the rail and remove the HUB.

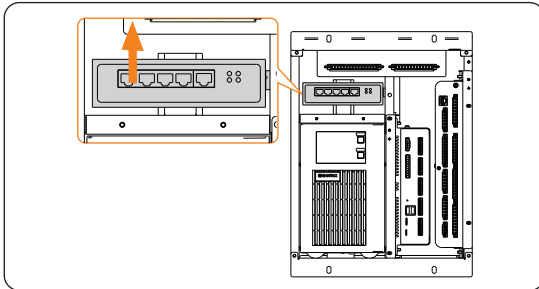

Figure 14-3 Sliding the HUB up

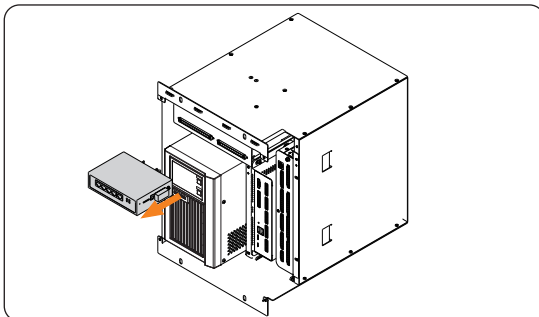

Figure 14-4 Removing the HUB

Step 4: Install a new HUB and connect the HUB cables according to HUB label and cable markings.

NOTICE!

- Please notice the direction of the HUB when installing.

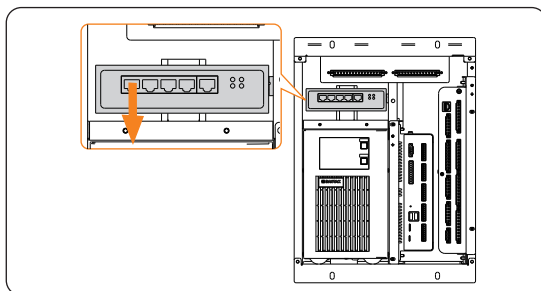

Figure 14-5 Sliding the HUB down

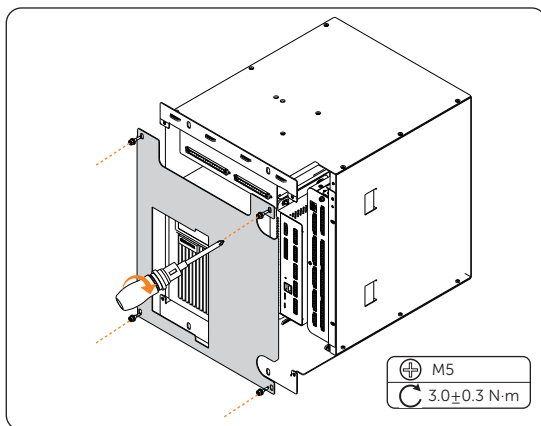

Figure 14-6 Installing the front panel

Checking after replacement

Step 1: Power on the system. For details, refer to "2.4 Power On".

Step 2: Check whether the indicator on the HUB is flashing green light.

15 Replacement of Air Conditioner

Prerequisites

- Fault locating:
 - a. View alarm information via cabinet screen, EMS1000 webpage, SolaXCloud App or troubleshooting manual.
 - b. Refer to the alarm handling suggestions in the alarm details.
 - c. Contact Solax and order replacement parts.
- Tools: Cross screwdriver, ladder.

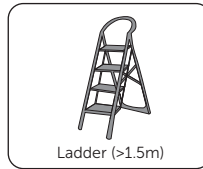
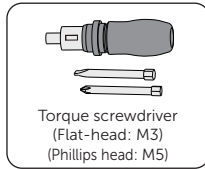

- At least two persons are required to replace the component.

WARNING!

- Before replacing the air conditioner, ensure that the system is powered off. Otherwise, electric shocks may occur.
- After the system powers off, there will still be the remaining electricity and heat which may cause electric shocks and body burns. Please wear personal protective equipment (PPE) and begin servicing the system five minutes after power off.
- Only qualified person can perform the maintenance for the device.

NOTICE!

- The replaced devices should be sent back to the local Solax warehouse.

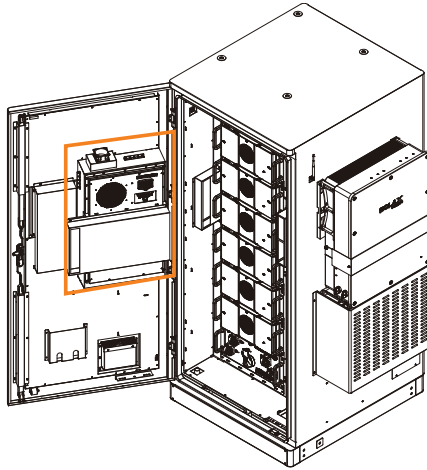

Figure 15-1 Position of the air conditioner

Procedure

- Step 1:** Loosen the fixing screws of the terminal blocks and remove the terminal blocks of air conditioner.
- Step 2:** Remove the front air duct and the side air ducts.

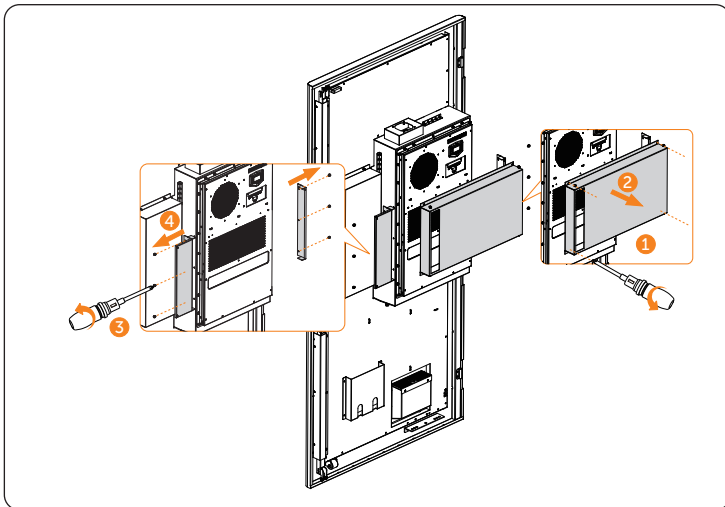

Figure 15-2 Removing the front air duct and side air ducts

Step 3: Unscrew the M5 screws on the air conditioner and remove the air conditioner.

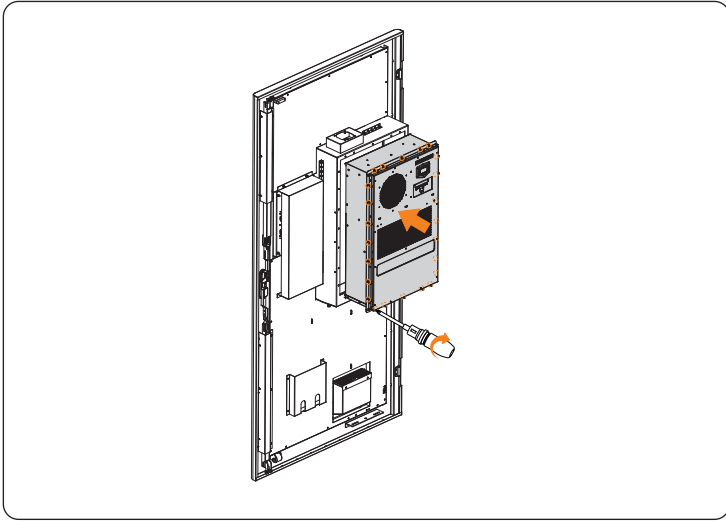

Figure 15-3 Removing the air conditioner

Step 4: Install a new air conditioner, connect the air conditioner cables and tighten the M3 fixing screws of the terminal blocks (torque: 0.5 ± 0.1 N·m) with a flat-head screwdriver.

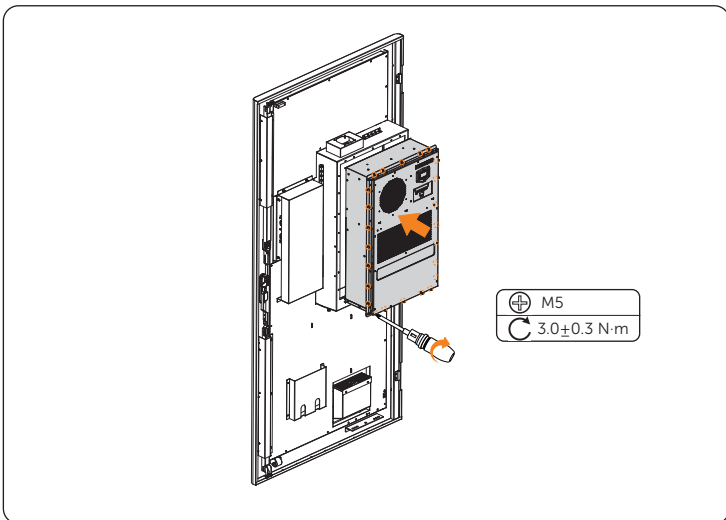

Figure 15-4 Installing the air conditioner

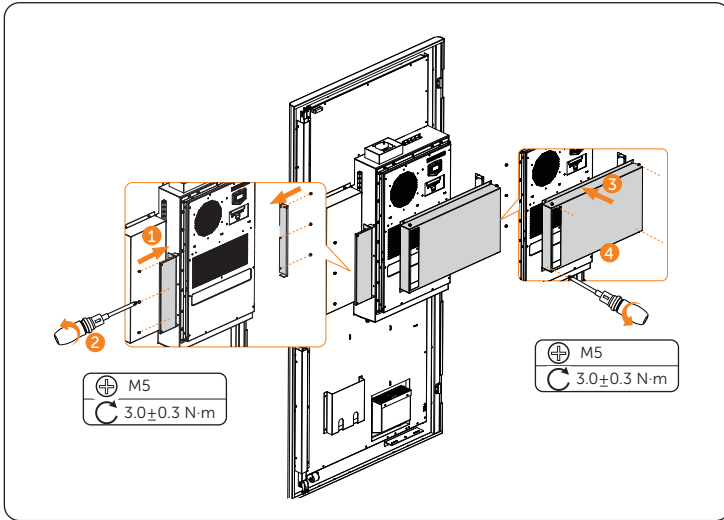

Figure 15-5 Installing the front air duct and side air ducts

Checking after replacement

For details of checking procedure after replacement, please refer to "28 Checking after Replacement".

16 Replacement of Temperature and Humidity Sensor

Prerequisites

- Fault locating:
 - a. View alarm information via cabinet screen, EMS1000 webpage, SolaXCloud App or troubleshooting manual.
 - b. Refer to the alarm handling suggestions in the alarm details.
 - c. Contact Solax and order replacement parts.
- Tools: Flat-head screwdriver, ladder.

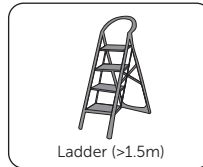
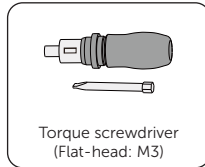

WARNING!

- Before replacing the temperature and humidity sensor, ensure that the system is powered off. Otherwise, electric shocks may occur.
- After the system powers off, there will still be the remaining electricity and heat which may cause electric shocks and body burns. Please wear personal protective equipment (PPE) and begin servicing the system five minutes after power off.
- Only qualified person can perform the maintenance for the device.

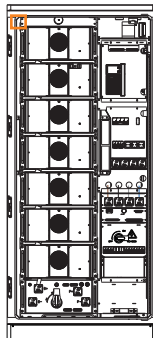

Figure 16-1 Position of the temperature and humidity sensor

Procedure

Step 1: Loosen the M3 fixing screws of the terminal blocks and remove the terminal blocks of temperature and humidity sensor.

Step 2: Loosen the M3 fixing screws of the fixture and remove the fixture along the rail outwards, and then remove the temperature and humidity sensor.

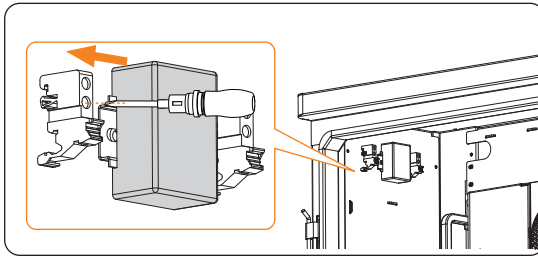

Figure 16-2 Removing the temperature and humidity sensor

Step 3: Install a new temperature and humidity sensor and secure it with the fixture, tighten the screw of the fixture.

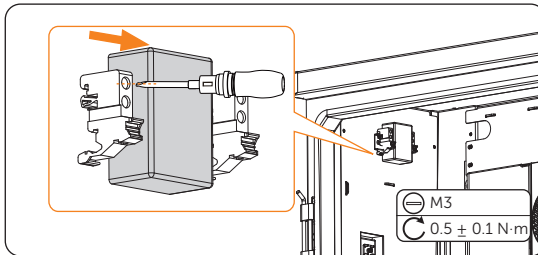

Figure 16-3 Removing the temperature and humidity sensor

Step 4: Connect the cables of temperature and humidity sensor and tighten the M3 fixing screws of the terminal blocks (torque: 0.5 ± 0.1 N·m).

Checking after replacement

Step 1: Power on the system. For details, refer to "2.4 Power On".

Step 2: Check whether the temperature and humidity is in normal range ($-30^{\circ}\text{C}\sim+55^{\circ}\text{C}$, 0-95%RH) via EMS1000 webpage or SolaX Cloud App.

17 Replacement of Door Sensor

Prerequisites

- Fault locating:
 - a. View alarm information via cabinet screen, EMS1000 webpage, SolaXCloud App or troubleshooting manual.
 - b. Refer to the alarm handling suggestions in the alarm details.
 - c. Contact Solax and order replacement parts.
- Tools: Cross screwdriver, ladder.

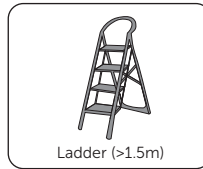
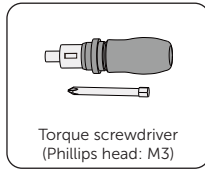

WARNING!

- Before replacing the door sensor, ensure that the system is powered off. Otherwise, electric shocks may occur.
- After the system powers off, there will still be the remaining electricity and heat which may cause electric shocks and body burns. Please wear personal protective equipment (PPE) and begin servicing the system five minutes after power off.
- Only qualified person can perform the maintenance for the device.

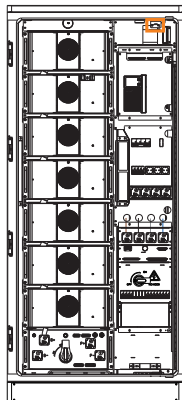

Figure 17-1 Position of the door sensor 1

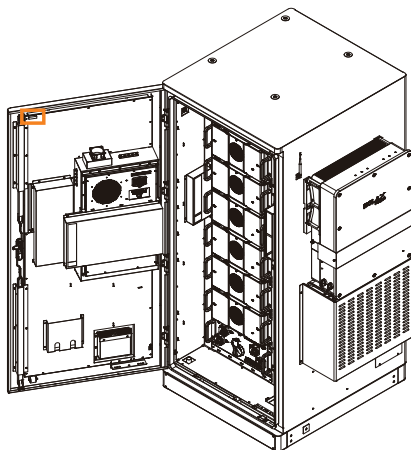

Figure 17-2 Position of the door sensor 2

Procedure

Step 1: Remove the cover of the door sensor.

Step 2: Remove the door sensor and disconnect the cable.

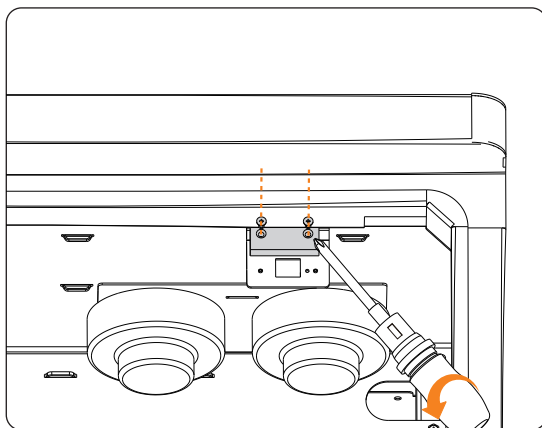

Figure 17-3 Removing the door sensor

NOTICE!

- This section take door sensor 1 as an example, remove door sensor 2 accordingly.

Step 3: Connect the cable and install the new door sensor, snap the cover.

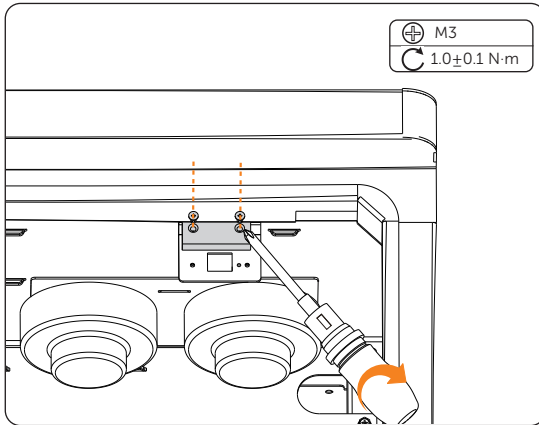

Figure 17-4 Installing the door sensor

Checking after replacement

For details of checking procedure after replacement, please refer to “28 Checking after Replacement”.

18 Replacement of Smoke Detector and Temperature Sensor

Prerequisites

- Fault locating:
 - a. View alarm information via cabinet screen, EMS1000 webpage, SolaXCloud App or troubleshooting manual.
 - b. Refer to the alarm handling suggestions in the alarm details.
 - c. Contact Solax and order replacement parts.
- Tools: Ladder.

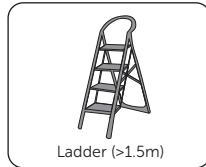

WARNING!

- Before replacing the smoke detector and temperature sensor, ensure that the system is powered off. Otherwise, electric shocks may occur.
- After the system powers off, there will still be the remaining electricity and heat which may cause electric shocks and body burns. Please wear personal protective equipment (PPE) and begin servicing the system five minutes after power off.
- Only qualified person can perform the maintenance for the device.

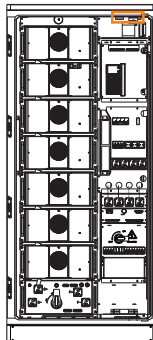

Figure 18-1 Position of the smoke detector and temperature sensor

Procedure

Step 1: Loosen the cover of the smoke detector and temperature sensor counterclockwise.

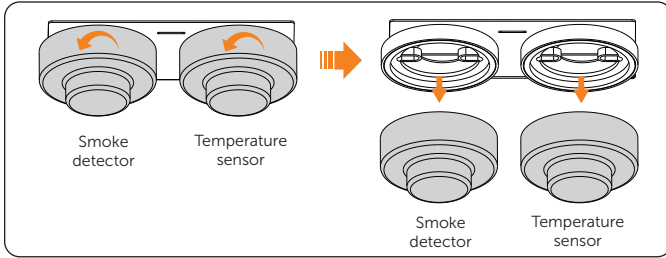

Figure 18-2 Removing the smoke detector and temperature sensor

Step 2: Install the new smoke detector and temperature sensor on the bases.

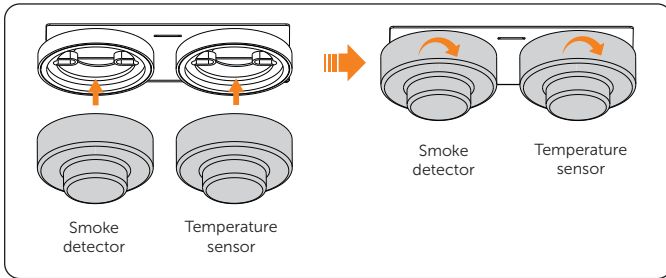

Figure 18-3 Installing the smoke detector and temperature sensor

Checking after replacement

For details of checking procedure after replacement, please refer to “28 Checking after Replacement”.

19 Replacement of Distribution Box

Prerequisites

- Fault locating:
 - a. View alarm information via cabinet screen, EMS1000 webpage, SolaXCloud App or troubleshooting manual.
 - b. Refer to the alarm handling suggestions in the alarm details.
 - c. Contact Solax and order replacement parts.
- Tools: Cross screwdriver, torque wrench

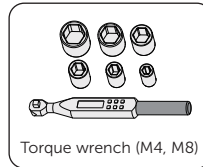
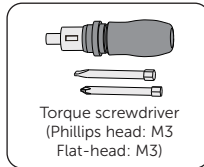

- At least two persons are required to replace the component.

WARNING!

- Before replacing the distribution box, ensure that the system is powered off. Otherwise, electric shocks may occur.
- After the system powers off, there will still be the remaining electricity and heat which may cause electric shocks and body burns. Please wear personal protective equipment (PPE) and begin servicing the system five minutes after power off.
- Only qualified person can perform the maintenance for the device.

NOTICE!

- The replaced devices should be sent back to the local Solax warehouse.

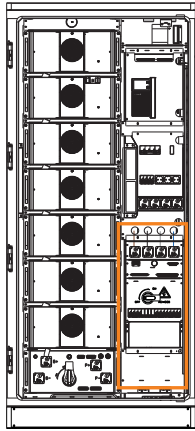

Figure 19-1 Position of the distribution box

Procedure

Step 1: Remove the terminal covers by pressing the buttons on both sides of the cover.

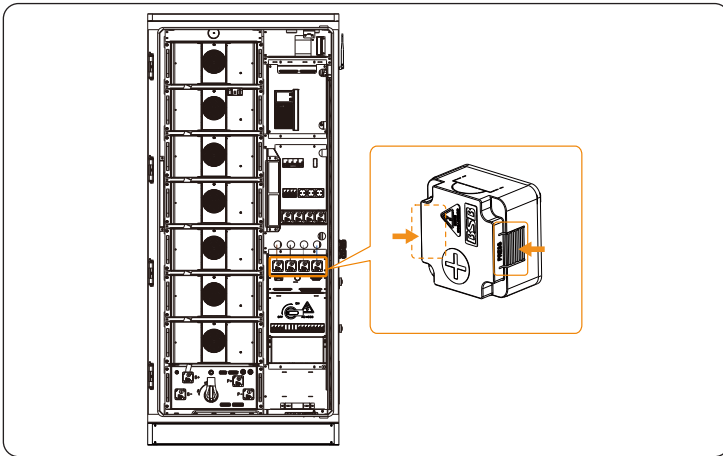

Figure 19-2 Removing the covers

NOTICE!

- Please keep the covers properly.

Step 2: Unscrew the M8 screws with torque wrench, disconnect the L1/L2/L3/N wires, and screw the M8 screws back.

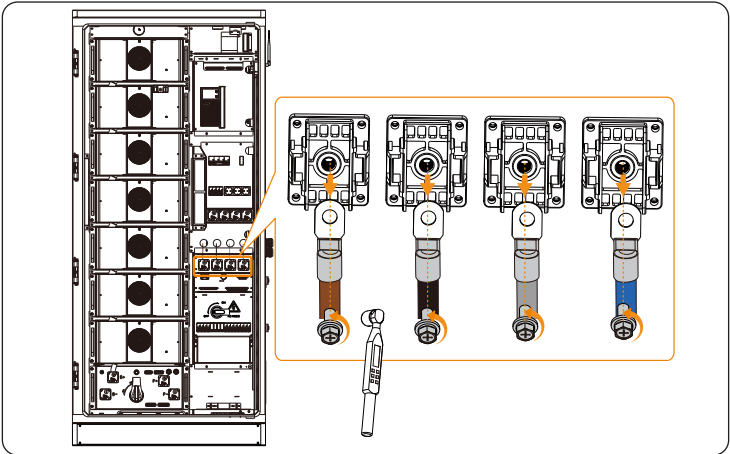

Figure 19-3 Disconnecting EPS wire

Step 3: Loosen the M4 screws to remove the cover.

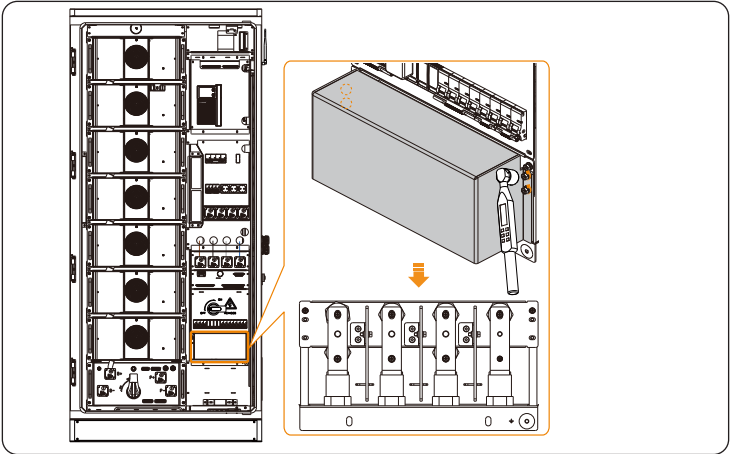

Figure 19-4 Removing cover

Step 4: Unscrew the M8 screws with torque wrench, disconnect the L1/L2/L3/N wires, and screw the M8 screws back. Install the cover back.

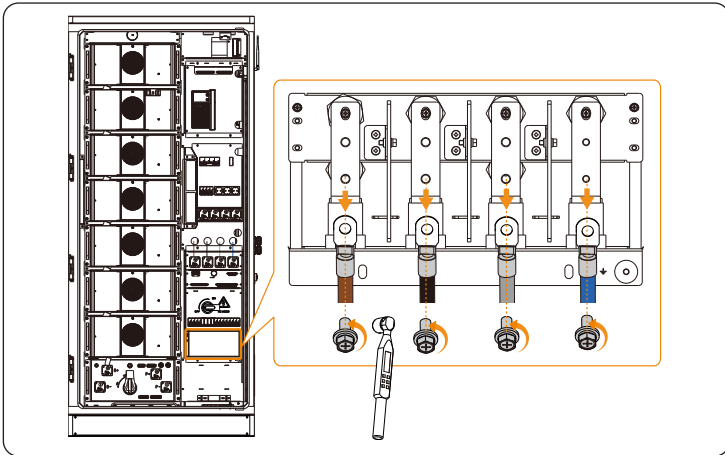

Figure 19-5 Disconnecting Grid wire

Step 5: Loosen the M3 fixing screws of the terminal blocks and remove the terminal blocks.

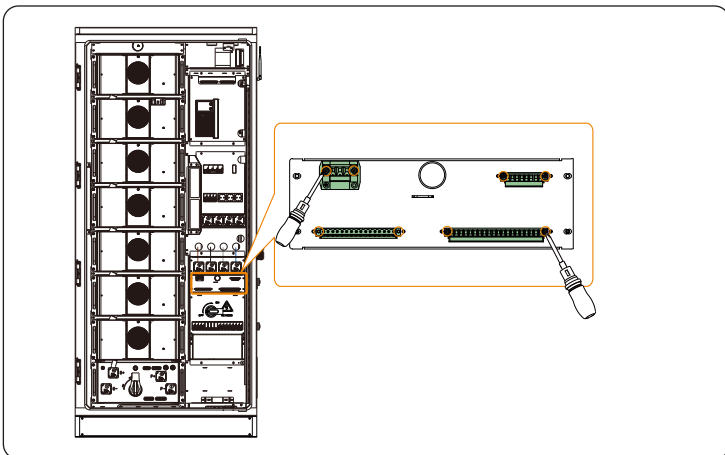

Figure 19-6 Removing the terminal blocks

Step 6: Loosen the M5 screws with torque wrench, remove the distribution box.

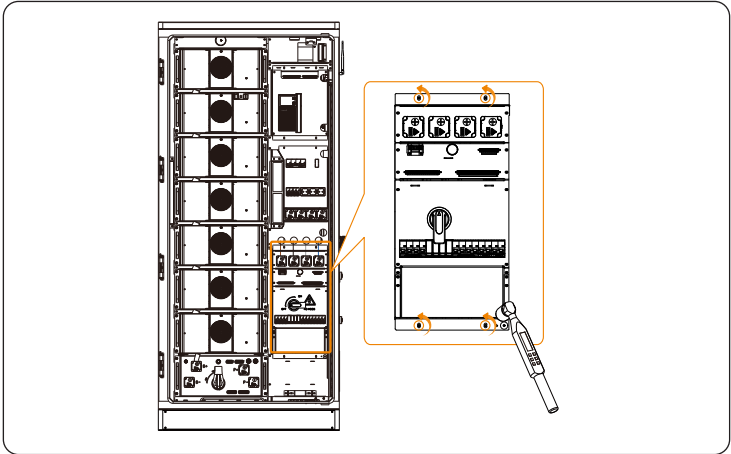

Figure 19-7 Removing the distribution box

Step 7: Install a new distribution box.

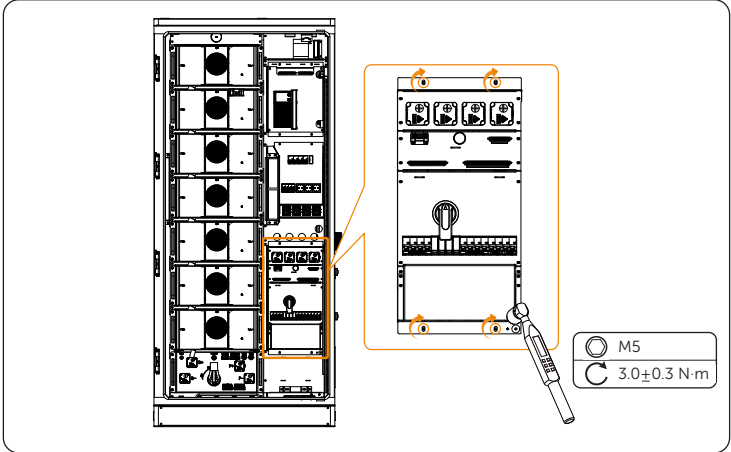

Figure 19-8 Installing new distribution box

Step 8: Remove the terminal covers by pressing the buttons on both sides of the cover. Connect the L1/L2/L3/N wires to the wire interface, and secure with M8 screws. Snap the covers back.

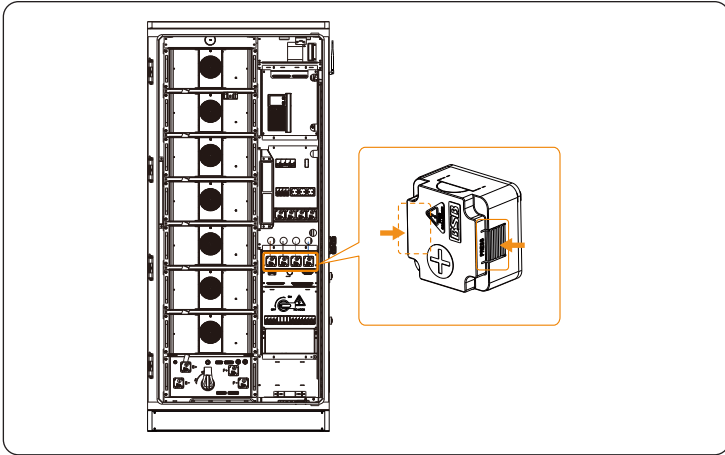

Figure 19-9 Removing the covers

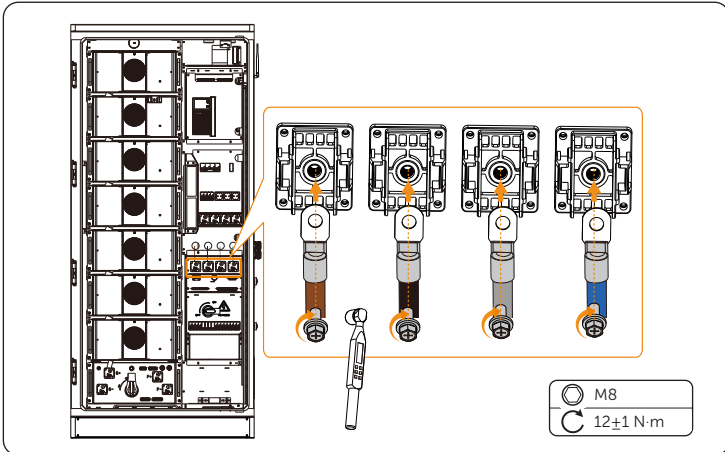

Figure 19-10 Connecting EPS wire

Step 9: Loosen the M5 screws to remove the cover. Connect the L1/L2/L3/N wires to the wire interface, and secure with M8 screws.

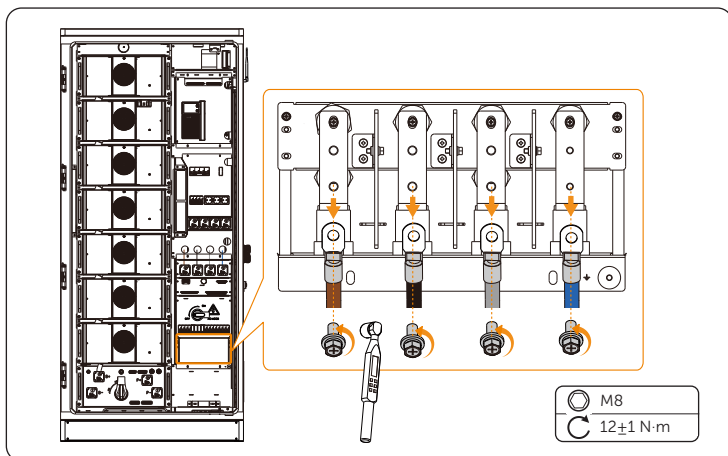

Figure 19-11 Connecting Grid wire

Step 10: Reattach the cover to the distribution box, and then correctly insert and tighten M4 screws.

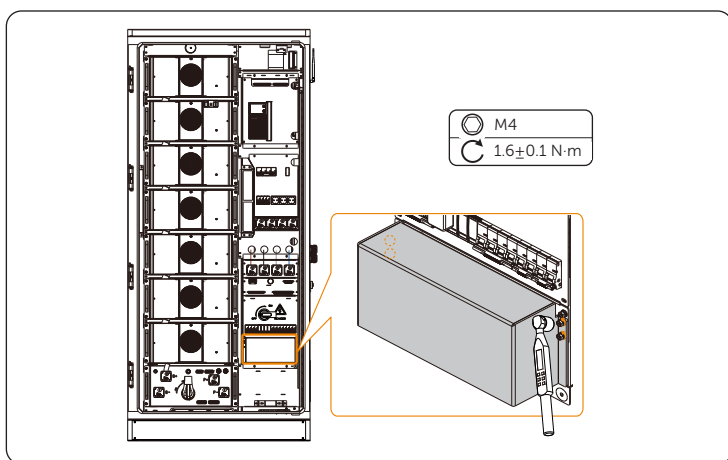

Figure 19-12 Reattaching the cover

Step 11: Plug the terminal blocks into the ports and tighten the M3 fixing screws of the terminal blocks.

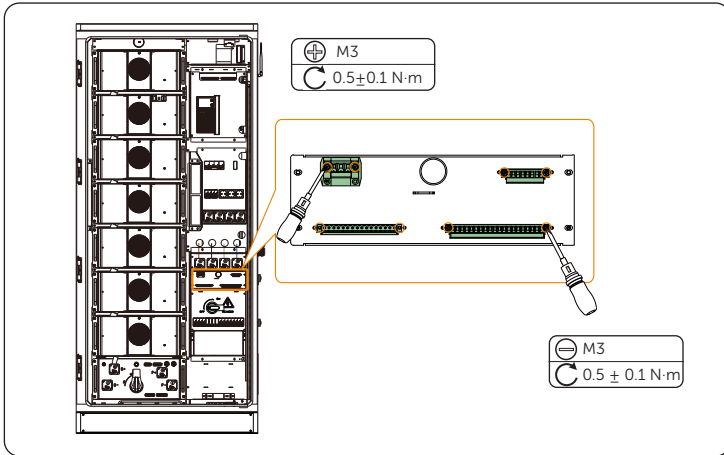

Figure 19-13 Connecting terminal blocks

Checking after replacement

For details of checking procedure after replacement, please refer to "28 Checking after Replacement".

20 Replacement of SPD Module

Prerequisites

- Fault locating:
 - a. View alarm information via cabinet screen, EMS1000 webpage, SolaXCloud App or troubleshooting manual.
 - b. Refer to the alarm handling suggestions in the alarm details.
 - c. Contact Solax and order replacement parts.
- Tools: Screwdriver, torque wrench.

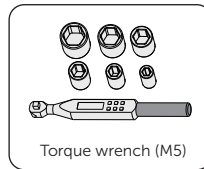
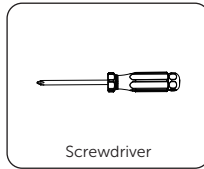

WARNING!

- Before replacing the SPD module, ensure that the system is powered off. Otherwise, electric shocks may occur.
- After the system powers off, there will still be the remaining electricity and heat which may cause electric shocks and body burns. Please wear personal protective equipment (PPE) and begin servicing the system five minutes after power off.
- Only qualified person can perform the maintenance for the device.

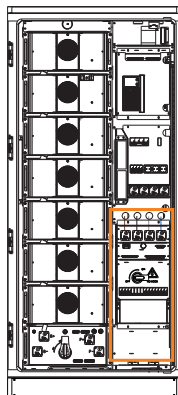

Figure 20-1 Position of the SPD module

Procedure

Step 1: Unscrew the M5 screws on the front panel of the distribution box and remove the front panel.

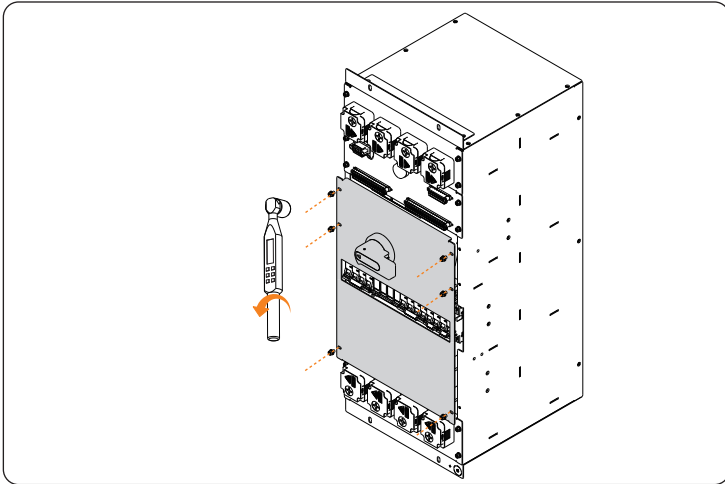

Figure 20-2 Removing the front panel

Step 2: Remove cables from the SPD module.

Step 3: Use a screwdriver to pry up the clip on the SPD and pull the SPD module out upwards.

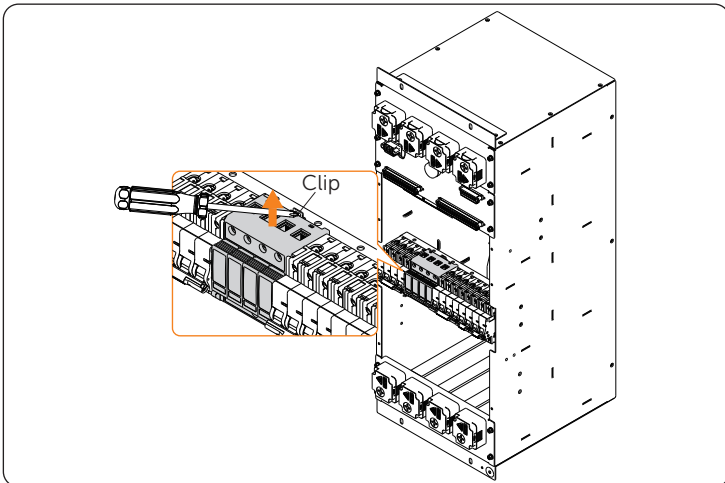

Figure 20-3 Removing the SPD module

Step 4: Install a new SPD module and connect the cables.

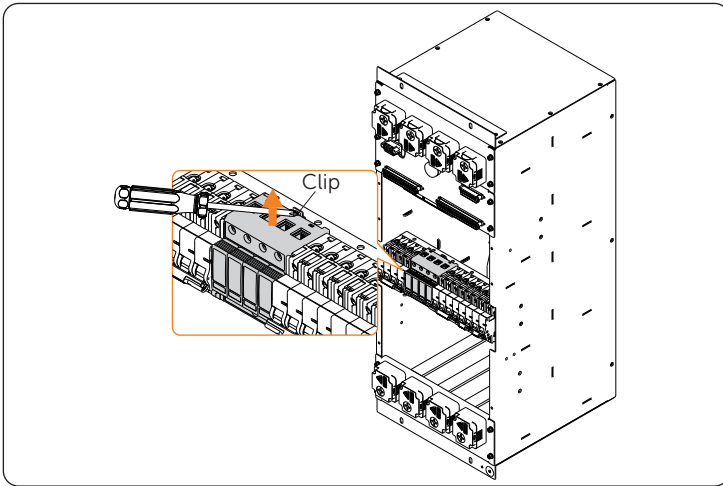

Figure 20-4 Installing SPD module

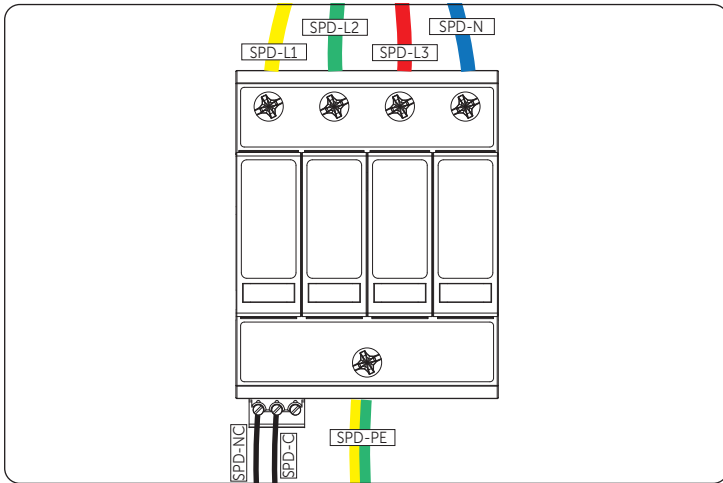

Figure 20-5 Connecting the SPD module cables

Step 5: Install the front panel.

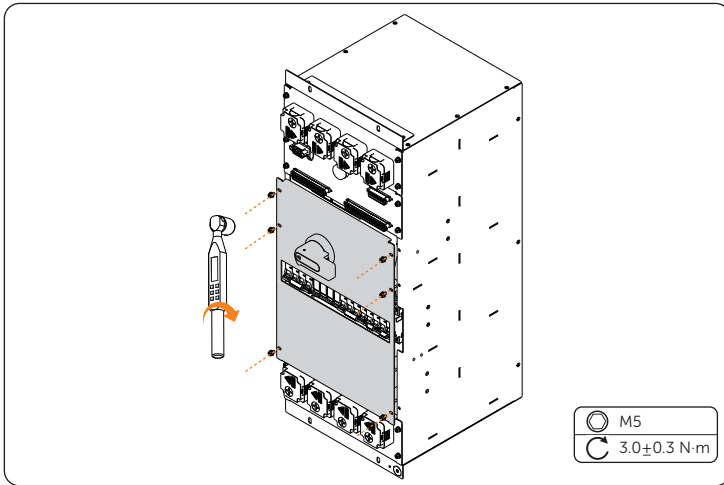

Figure 20-6 Installing the front panel

Checking after replacement

Step 1: Power on the system. For details, refer to “2.4 Power On”.

Step 2: Check whether the indicator of the SPD module is green light.

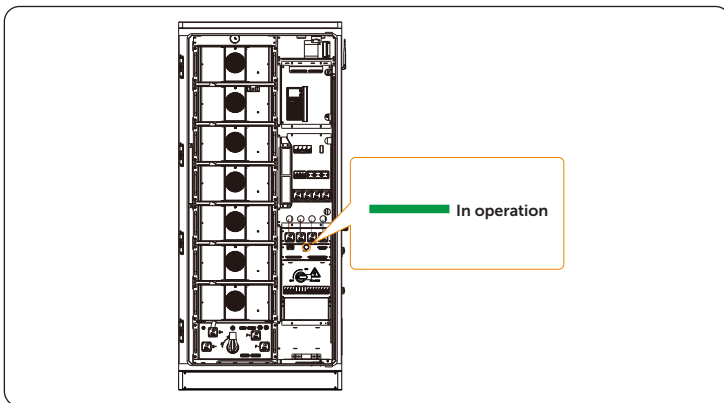

Figure 20-7 SPD module indicator

Step 3: Check whether the status of the SPD module is normal via EMS1000 webpage or SolaX Cloud App.

21 Replacement of Audible and Visible Alarm

Prerequisites

- Fault locating:
 - a. View alarm information via cabinet screen, EMS1000 webpage, SolaXCloud App or troubleshooting manual.
 - b. Refer to the alarm handling suggestions in the alarm details.
 - c. Contact Solax and order replacement parts.
- Tools: Cross screwdriver, ladder.

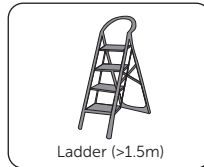
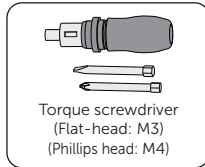

WARNING!

- Before replacing the audible and visible alarm, ensure that the system is powered off. Otherwise, electric shocks may occur.
- After the system powers off, there will still be the remaining electricity and heat which may cause electric shocks and body burns. Please wear personal protective equipment (PPE) and begin servicing the system five minutes after power off.
- Only qualified person can perform the maintenance for the device.

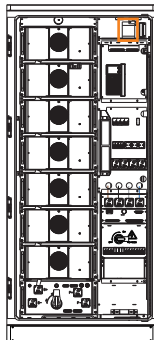

Figure 21-1 Position of the audible and visible alarm

Procedure

Step 1: Remove the cover of audible and visible alarm.

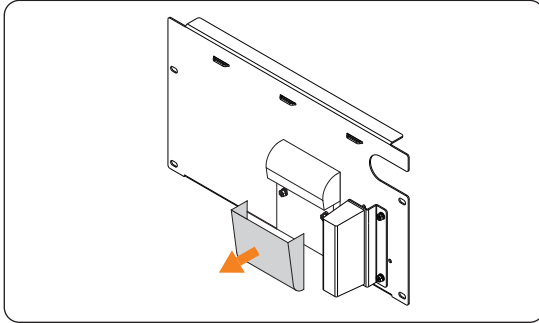

Figure 21-2 Removing the cover

Step 2: Loosen the M4 fixing screws of the cables and disconnect the cables. Remove the audible and visible alarm.

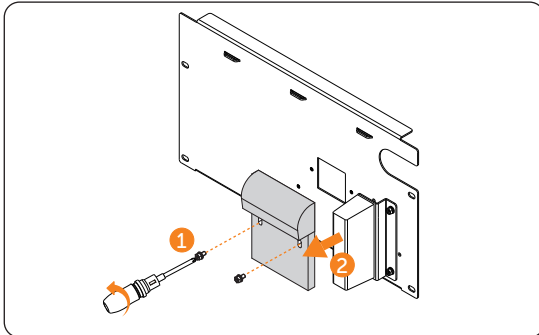

Figure 21-3 Removing the audible and visible alarm

Step 3: Install a new audible and visible alarm, connect the cables and tighten the M3 fixing screws with a flat-head screwdriver (torque: 0.5 ± 0.1 N·m). Snap the cover.

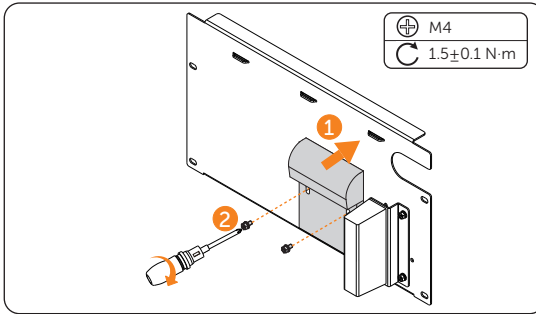

Figure 21-4 Installing the audible and visible alarm

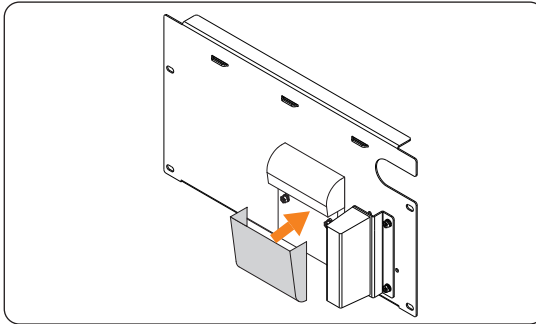

Figure 21-5 Snap the cover

Checking after replacement

- Step 1:** Power on the system. For details, refer to "2.4 Power On".
- Step 2:** Use the IO module to control the D03 close, check whether the audible and visible alarm will buzz and light up.

22 Replacement of Toxic Gases Detector

Prerequisites

- Fault locating:
 - a. View alarm information via cabinet screen, EMS1000 webpage, SolaXCloud App or troubleshooting manual.
 - b. Refer to the alarm handling suggestions in the alarm details.
 - c. Contact Solax and order replacement parts.
- Tools: Ladder.

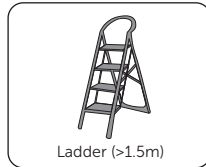

WARNING!

- Before replacing the toxic gases detector, ensure that the system is powered off. Otherwise, electric shocks may occur.
- After the system powers off, there will still be the remaining electricity and heat which may cause electric shocks and body burns. Please wear personal protective equipment (PPE) and begin servicing the system five minutes after power off.
- Only qualified person can perform the maintenance for the device.

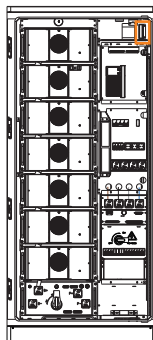

Figure 22-1 Position of the toxic gases detector

Procedure

Step 1: Unplug the cables in the top of the toxic gases detector and remove the toxic gases detector from the base.

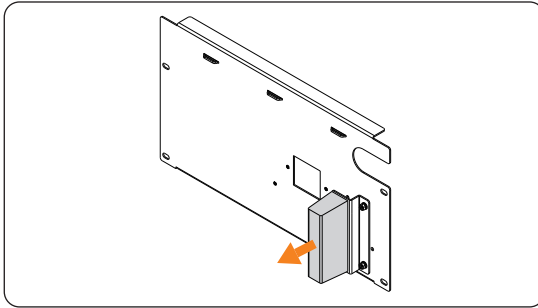

Figure 22-2 Removing the toxic gases detector

Step 2: Snap a new toxic gases detector on the base and plug the cables.

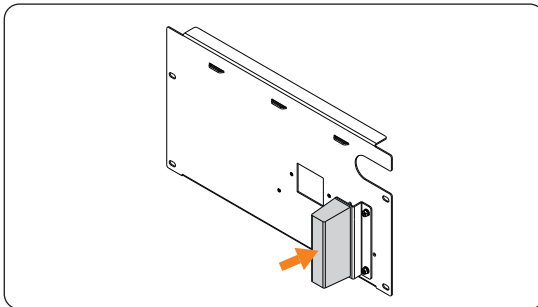

Figure 22-3 Installing the toxic gases detector

Checking after replacement

For details of checking procedure after replacement, please refer to “28 Checking after Replacement”.

23 Replacement of Water Sensor

Prerequisites

- Fault locating:
 - a. View alarm information via cabinet screen, EMS1000 webpage, SolaXCloud App or troubleshooting manual.
 - b. Refer to the alarm handling suggestions in the alarm details.
 - c. Contact Solax and order replacement parts.
- Tools: Elbow cross screwdriver.

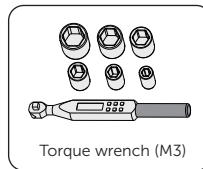
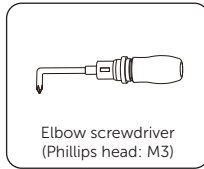

WARNING!

- Before replacing the water sensor, ensure that the system is powered off. Otherwise, electric shocks may occur.
- After the system powers off, there will still be the remaining electricity and heat which may cause electric shocks and body burns. Please wear personal protective equipment (PPE) and begin servicing the system five minutes after power off.
- Only qualified person can perform the maintenance for the device.

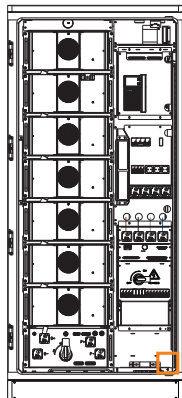

Figure 23-1 Position of the water sensor

Procedure

Step 1: Unscrew the M3 screws on the water sensor and remove the water sensor.

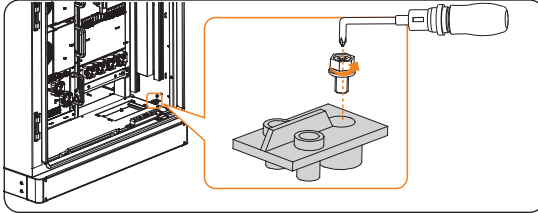

Figure 23-2 Removing the water sensor

Step 2: Unscrew the M3 nut counterclockwise to remove the water sensor cable.

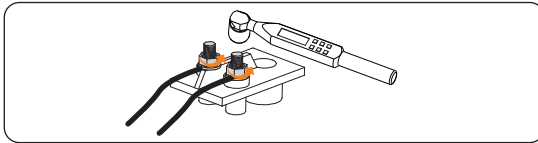

Figure 23-3 Removing the cable

Step 3: Install a new water sensor and connect the cable.

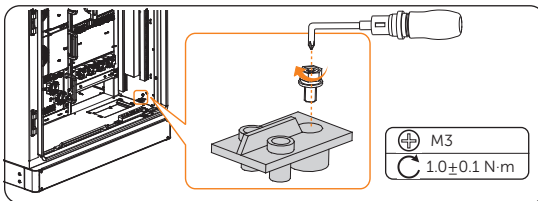

Figure 23-4 Installing the water sensor

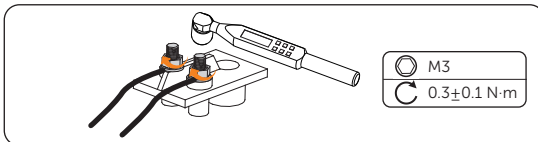

Figure 23-5 Connecting the cable

Checking after replacement

Use a multimeter to measure the water sensor ON-OFF status (OFF for normal, ON for abnormal).

24 Replacement of EPS Switch

Prerequisites

- Fault locating:
 - a. View alarm information via cabinet screen, EMS1000 webpage, SolaXCloud App or troubleshooting manual.
 - b. Refer to the alarm handling suggestions in the alarm details.
 - c. Contact Solax and order replacement parts.
- Tools: Cross screwdriver.

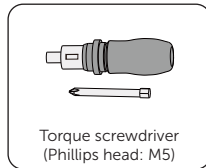

WARNING!

- Before replacing the EPS switch, ensure that the system is powered off. Otherwise, electric shocks may occur.
- After the system powers off, there will still be the remaining electricity and heat which may cause electric shocks and body burns. Please wear personal protective equipment (PPE) and begin servicing the system five minutes after power off.
- Only qualified person can perform the maintenance for the device.

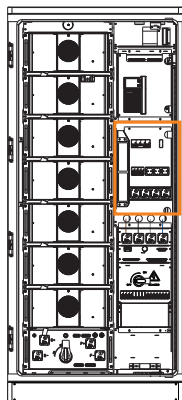

Figure 24-1 Position of the EPS switch

Procedure

Step 1: Unscrew the M5 screws on the front panel and remove the front panel.

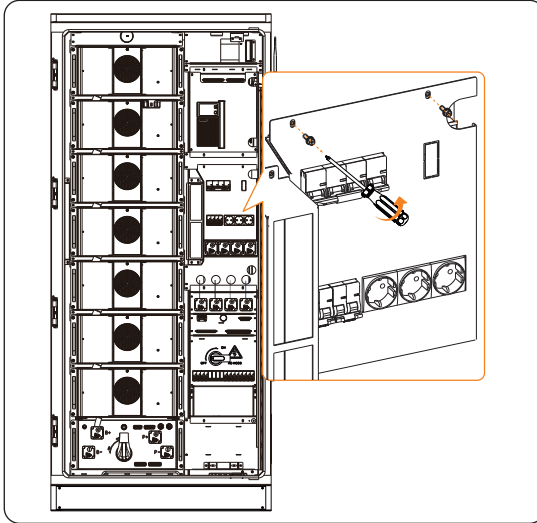

Figure 24-2 Removing the front panel

Step 2: Remove cables from the EPS switch and remove the EPS switch.

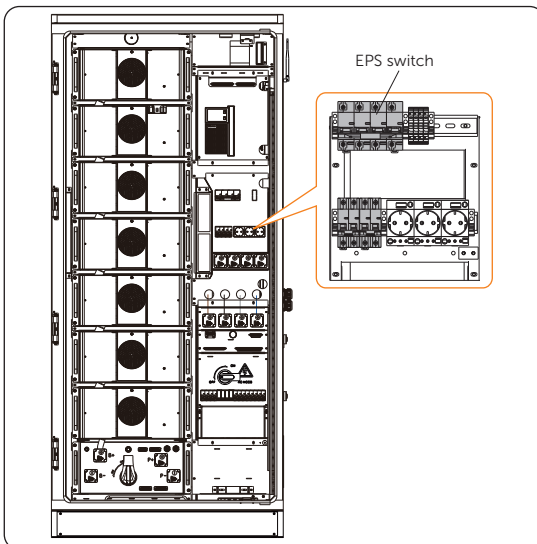

Figure 24-3 Removing the EPS switch

Step 3: Install a new EPS switch and connect the cables.

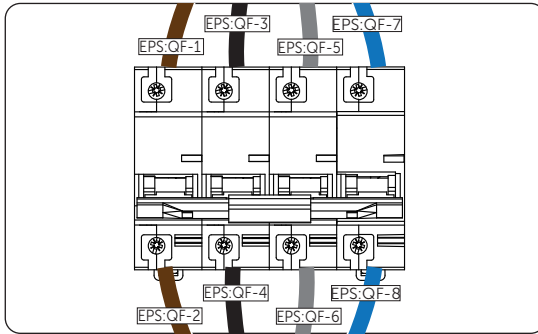

Figure 24-4 Connecting EPS switch cables

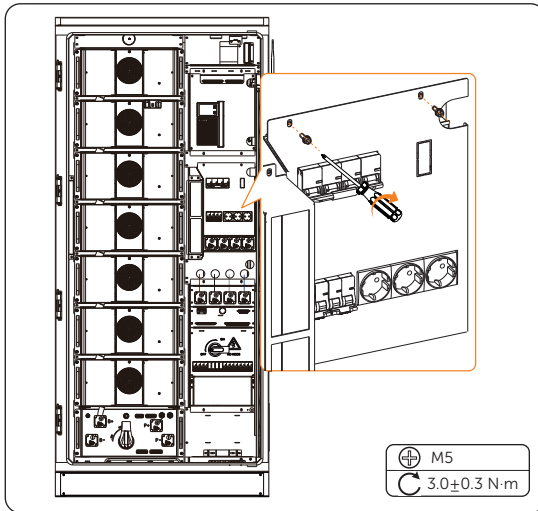

Figure 24-5 Installing the front panel

Checking after replacement

Check whether the EPS switch can be switched on and off normally.

25 Replacement of UPS Switch

Prerequisites

- Fault locating:
 - a. View alarm information via cabinet screen, EMS1000 webpage, SolaXCloud App or troubleshooting manual.
 - b. Refer to the alarm handling suggestions in the alarm details.
 - c. Contact Solax and order replacement parts.
- Tools: Cross screwdriver.

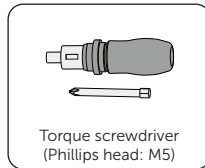

WARNING!

- Before replacing the UPS switch, ensure that the system is powered off. Otherwise, electric shocks may occur.
- After the system powers off, there will still be the remaining electricity and heat which may cause electric shocks and body burns. Please wear personal protective equipment (PPE) and begin servicing the system five minutes after power off.
- Only qualified person can perform the maintenance for the device.

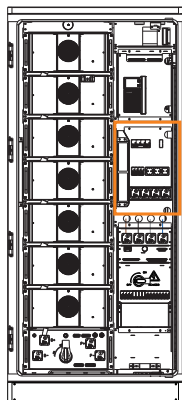

Figure 25-1 Position of UPS switch

Procedure

Step 1: Unscrew the M5 screws on the front panel and remove the front panel.

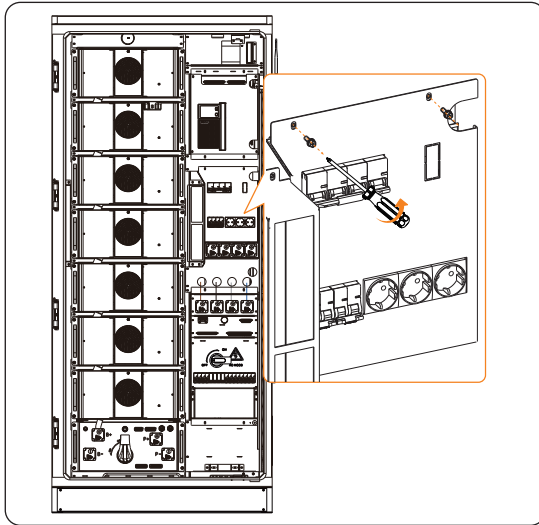

Figure 25-2 Removing the front panel

Step 2: Remove cables from the UPS switch and remove the UPS switch.

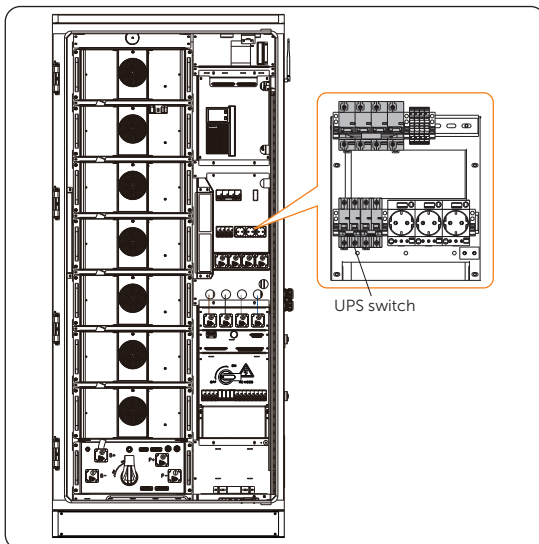

Figure 25-3 Removing the UPS switch

Step 3: Install a new UPS switch and connect the cables.

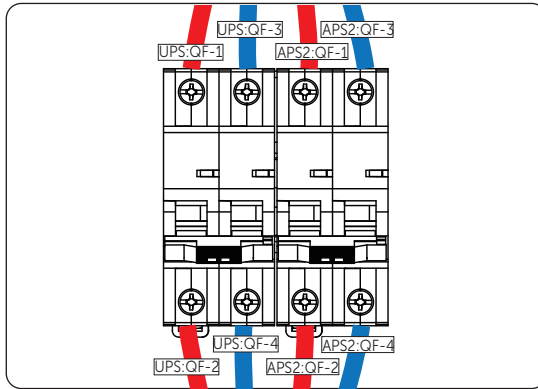

Figure 25-4 Connecting UPS switch cables

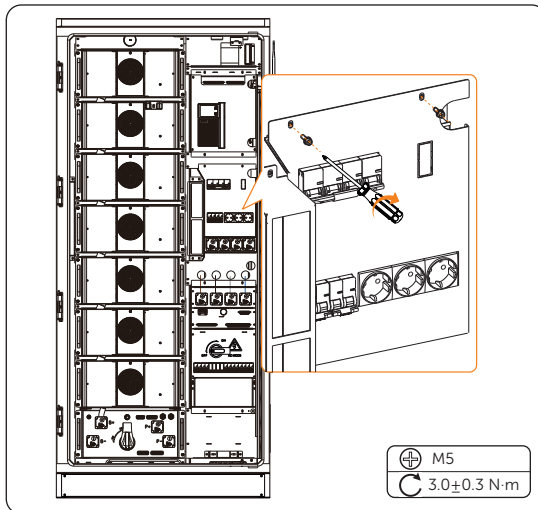

Figure 25-5 Installing the front panel

Checking after replacement

Check whether the UPS switch can be switched on and off normally.

26 Replacement of Inverter Fans

Prerequisites

- Fault locating:
 - a. View alarm information via cabinet screen, EMS1000 webpage, SolaXCloud App or troubleshooting manual.
 - b. Refer to the alarm handling suggestions in the alarm details.
 - c. Contact Solax and order replacement parts.
- Tools: Cross screwdriver, diagonal plier.

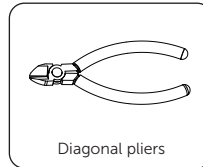
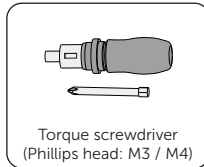

WARNING!

- Before replacing the fan, ensure that the system is powered off. Otherwise, electric shocks may occur.
- After the system powers off, there will still be the remaining electricity and heat which may cause electric shocks and body burns. Please wear personal protective equipment (PPE) and begin servicing the system 30 minutes after power off.
- Only qualified person can perform the maintenance for the device.

Procedure

Step 1: Loosen the M4 screws on the right side of the inverter with a cross screwdriver, and the nuts on the left side of the inverter.

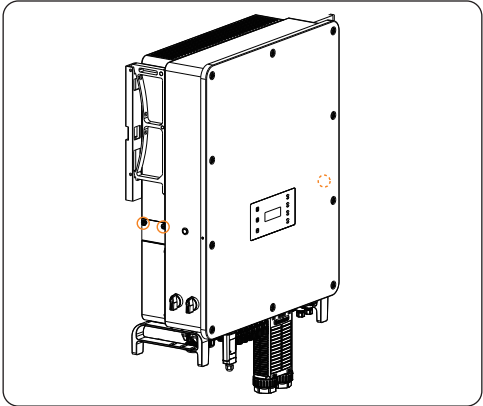

Figure 26-1 Dismantling screws

Step 2: Pull out the fan bracket, stop at the position about 150 mm, then press the protruding block with a screwdriver to release the fan waterproof connectors, then pull the fan bracket again to pull out the whole bracket.

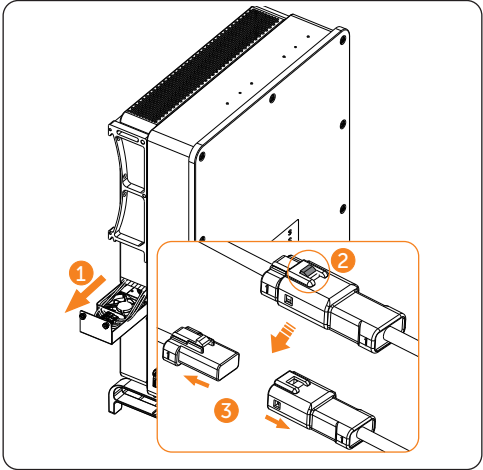

Figure 26-2 Releasing the fan waterproof connectors

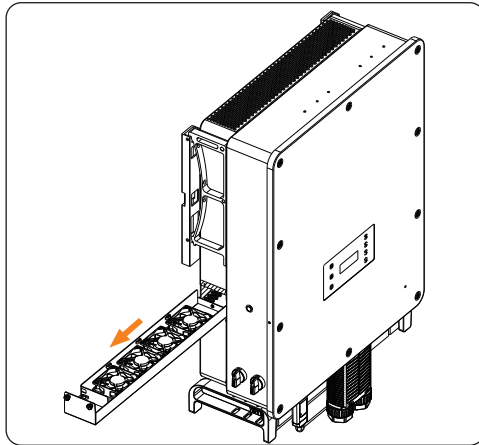

Figure 26-3 Pulling put the whole fan bracket

Step 3: Clean, repair, or replace the fan.

- a. Identify the fan to be replaced by cable markings.

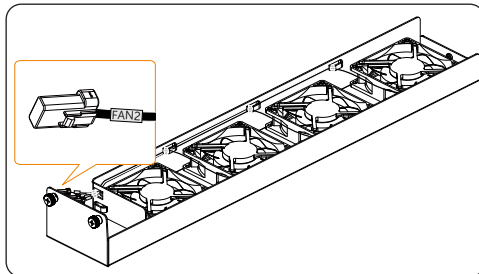

Figure 26-4 Identify the fan to be replaced

- b. Cut the cable ties with diagonal plier.

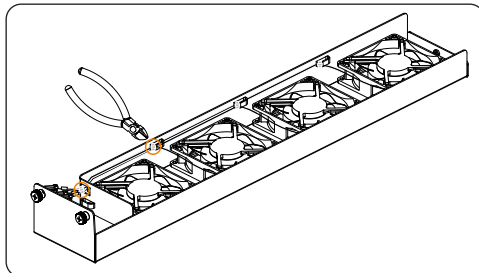

Figure 26-5 Cut the cable ties

- c. Unscrew the M3 screws on the bottom of the bracket.

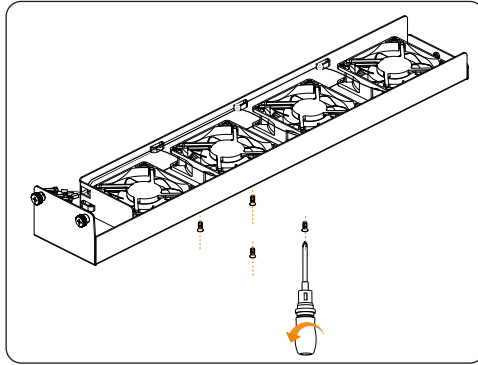

Figure 26-6 Unscrew the fan screws

- d. Remove the damaged fan, replace a new fan.

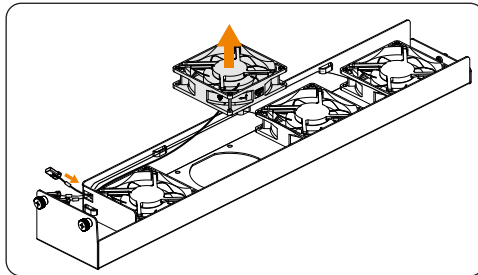

Figure 26-7 Remove the damaged fan

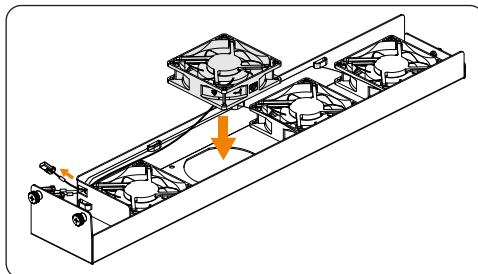

Figure 26-8 Replace a new fan

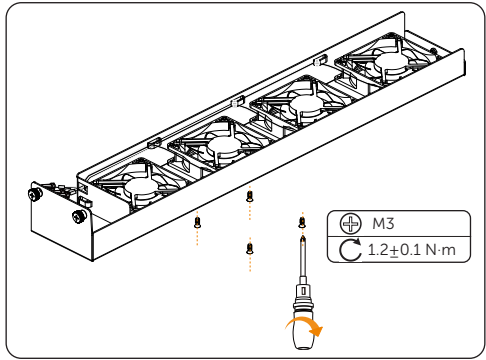

Figure 26-9 Lock the screws

- e. Secure the cable with the cable ties.

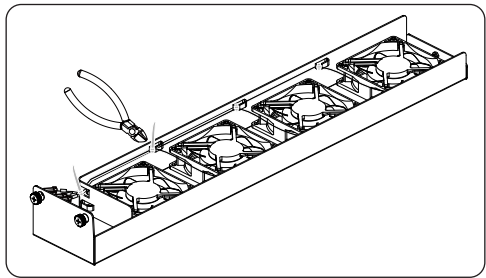

Figure 26-10 Unscrew the fan screws

- f. Slide the fan bracket into the inverter, connect fan waterproof connectors.

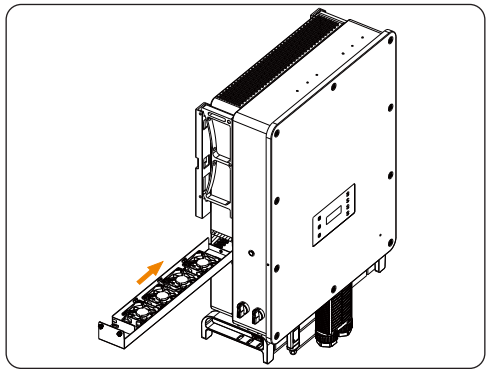

Figure 26-11 Slide the fan bracket

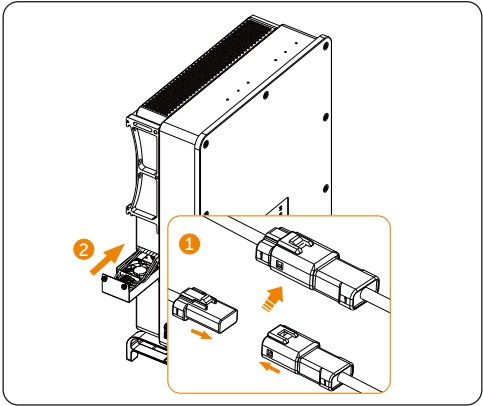

Figure 26-12 Connect fan waterproof connectors

Step 4: Lock the fixing screws.



Figure 26-13 Lock the screws

Checking after replacement

For details of checking procedure after replacement, please refer to "28 Checking after Replacement".

27 Replacement of Inverter

Prerequisites

- Fault locating:
 - a. View alarm information via cabinet screen, EMS1000 webpage, SolaXCloud App or troubleshooting manual.
 - b. Refer to the alarm handling suggestions in the alarm details.
 - c. Contact Solax and order replacement parts.
- Tools: Removal tool for PV connectors, cross screwdriver, torque wrench, crane.

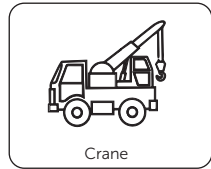
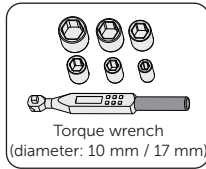
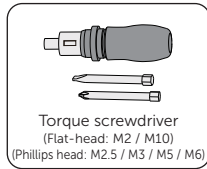
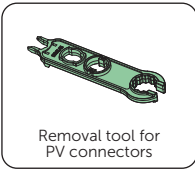

WARNING!

- Before replacing the inverter, ensure that the system is powered off. Otherwise, electric shocks may occur.
- After the system powers off, there will still be the remaining electricity and heat which may cause electric shocks and body burns. Please wear personal protective equipment (PPE) and begin servicing the system 30 minutes after power off.
- Only qualified person can perform the maintenance for the device.

NOTICE!

- The replaced devices should be sent back to the local Solax warehouse.

Procedure

Please refer to *AELIO-P50B100 and AELIO-P60B100 User Manual* for inverter replace procedures.

Checking after replacement

Step 1: Power on the system. For details, refer to "2.4 Power On".

Step 2: Check whether the inverter LCD lights up and ensure the functions are restored.

28 Checking after Replacement

- Step 1:** Check that the replacement parts are installed and connected correctly and securely.
- Step 2:** Check the cable jacket for damage, especially the cable jacket connecting with the metal parts.
- Step 3:** Power on the system. For details, refer to ["2.4 Power On"](#).
- Step 4:** Check the running status of the system and ensure that the functions are restored.
- Step 5:** Check whether the alarm status is displayed as resolved and no new alarms are generated via the cabinet screen, EMS1000 webpage or SolaX Cloud App.

Contact Information



UNITED KINGDOM



Unit C-D Riversdale House, Riversdale
Road, Atherstone, CV9 1FA



+44 (0) 2476 586 998



service.uk@solaxpower.com



TURKEY



Fevzi Çakmak mah. aslım cd. no 88 A
Karatay / Konya / Türkiye



service.tr@solaxpower.com



USA



3780 Kilroy Airport Way, Suite 200, Long
Beach, CA, US 90806



+1 (408) 690 9464



info@solaxpower.com



POLAND



WARSAW AL. JANA P. II 27. POST



+48 662 430 292



service.pl@solaxpower.com



ITALY



+39 011 19800998



support@solaxpower.it



PAKISTAN



service.pk@solaxpower.com



AUSTRALIA



21 Nicholas Dr, Dandenong South VIC 3175



+61 1300 476 529



service@solaxpower.com.au



GERMANY



Am Tullnaupark 8, 90402 Nürnberg,
Germany



+49 (0) 6142 4091 664



service.eu@solaxpower.com



service.dach@solaxpower.com



NETHERLANDS



Twekkeler-Es 15 7547 ST Enschede



+31 (0) 8527 37932



service.eu@solaxpower.com



service.bnl@solaxpower.com



SPAIN



+34 9373 79607



tecnico@solaxpower.com



BRAZIL



+55 (34) 9667 0319



info@solaxpower.com



SOUTH AFRICA



service.za@solaxpower.com



SolaX Power Network Technology (Zhejiang) Co., Ltd.

Add.: No. 278, Shizhu Road, Chengnan Sub-district, Tonglu County,
Hangzhou, Zhejiang, China
E-mail: info@solaxpower.com

